



***Richpeace***®

## **Magic Ink-jet Plotter User's Manual**



## Content

<b>Make sure to operate safely and accurately .....</b>	<b>I</b>
Safe Notice I.....	II
Safe Notice II.....	IV
<b>Chapter1 Install Plotter .....</b>	<b>1</b>
1.1 Check accessory.....	2
1.2 Technical parameter.....	4
1.3 Structure and installation of new model plotter.....	5
1.3.1 Structure and parts functions.....	5
1.3.2 Installation.....	6
1.3.3 Install paper .....	9
1.3.4 Paper cutting.....	13
1.4 Structure and installation.....	13
1.4.1 Structure and parts functions of common model.....	14
1.4.2 Installation.....	17
1.4.3 Install paper .....	20
1.4.4 Install ink box .....	25
1.5 Structure and installation of MJ135 plotter.....	26
1.5.1 Structure and parts functions.....	26
1.5.2 Installation.....	27
1.6 Connect to computer.....	28
<b>Chapter2 Basic setting and operation .....</b>	<b>30</b>
2.1 Origin setting.....	31
2.2 Plot test graph.....	32
2.3 Delete file .....	33
2.4 Sensor check .....	34
2.5 Keyboard check .....	35
2.6 Collection start and stop.....	36
2.7 Print head cleaning times.....	37
The function used before the settings file printed,print head cleaning times,setting range"1`5" .	37
2.8Version Info .....	38
<b>Chapter3 Plot .....</b>	<b>39</b>
3.1 Plotcenter .....	40
3.2 File.....	40
3.3 Tools .....	45
3.4 Language .....	47
3.5 Setup.....	48
3.6 Calibration .....	54
3.7 Plot sequence .....	55
3.8 Print preview .....	55
3.9Operation after plotting.....	56
<b>Chapter4 trouble shooting .....</b>	<b>57</b>
4.1 Error indication .....	58
4.2 Note.....	58

## Make sure to operate safely and accurately

- In order to operating the plotter safely and accurately, please read the manual carefully before using the plotter.
- In order to reading it quickly when you needed, please put it at the place where you can get it conveniently after reading carefully.
- Children are forbidden to touch the plotter.
- Please follow the operation explanations strictly when you operate the plotter.

General Usage in the manual

In order to using the plotter safely and accurately and avoiding body injured and property damaged, the manual prescribes three kinds of safe notice proceedings, please understand the difference.



### DANGER

The notice means DANGER, if ignored, it maybe cause deadliness or serious damage to operator.



### WARNING







The notice means WARNING, if ignored, it maybe cause deadliness or serious damage to operator.



### CAUTION

The notice means CAUTION, if ignored, it maybe cause damage to operator or weaken physical capability of the plotter.

### Explanation of Safety Symbols

		It means caution or warning, the place where should be careful or warned will be put the symbol or symbol with text indicate.
		It means action should be prohibited, the place where should be prohibited will be put the symbol or symbol with text indicate.
		It means the action must be carried out. The action that should be carried out will be put this symbol or symbol with text indicate.

## Safe Notice I

### WARNING

If the smoke happens from the plotter that due to too much hot and strange smell, or other reasons cause the machine can't work normally, please stop using it. Turn off the power, and pull out the power cable from the electrical outlet.

Continuing to use the plotter under these situations might cause fire or electrical attack.

Make sure the plotter is not smoking any longer, please contact the salesman or Richpeace authorized agent for maintaining.

Please don't maintain the plotter yourself; it is very danger to maintain by unfamiliar person.



Forbidden

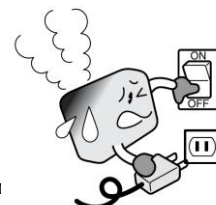

It is forbidden to disassemble, maintain or refit the plotter.

These actions might cause electrical attack or fire by creepage.

Touch the high voltage accessory of the plotter might cause electrical attack.

If it need to be maintained, please contact the salesman or Richpeace authorized local agent.



Disassemble  
Forbidden



Don't use the machine in the place where has water, rain and snow.

These places might cause electrical attack or fire by creepage.



Water avoided



Take Care

Electrical Attack

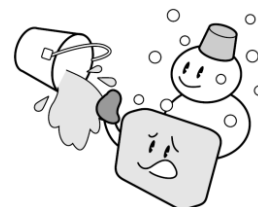

Make sure the plotter is grounding.

If it hasn't ground wire, the operator might get electrical attack by creepage.



Grounding

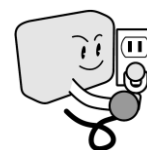

Don't connect the machine with non-stable power.

Use different power might cause electrical attack or fire by creepage.



Forbidden



Don't use the broken electrical wire.

Use the broken electrical wire might cause electrical attack or fire by creepage.

Change it to a new electrical wire.

Don't let the dust and the metal material adhibit to the power plug.  
The dirty power plug might cause electrical attack or fire by creepage.



Forbidden

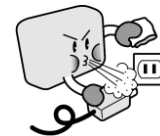

Take Care

Electrical Attack

Please don't touch the print head and the moving parts when plotting.  
These actions might cause body injured.



Don't touch

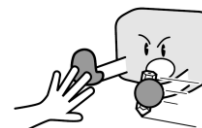

When the plotter stops working, please keep your hand and hair far away from the print head and the moving parts, because the plotter that had received data might move suddenly.  
These actions might cause body injured.



Keep Distance

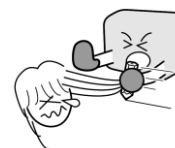

## Safe Notice II

### TAKE CARE

Don't use or hold the machine under sunshine, or the places where have air-condition and heater blowing directly.

These places might weaken the capability of the plotter.

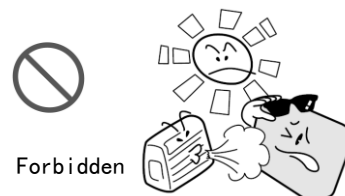

Don't use the plotter at the place where is dusty or damp especially.

Using the plotter in these places might weaken the capability of the machine.

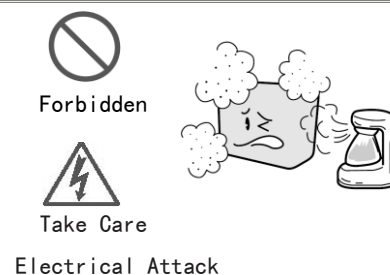

Don't use the plotter at the places that have mechanical shake or electrical noise.

Using the plotter in these places might weaken the capability of the plotter.

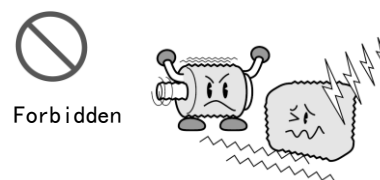

Don't put the container fill with water or other liquid on the plotter.

Inflooding liquid on the plotter might cause the electrical attack or fire by creepage.

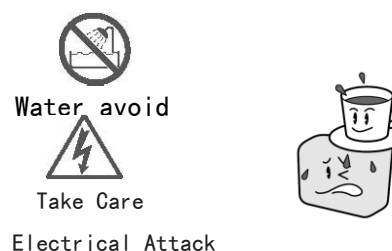

If there are water or eyewinker in the machine, please stop using it. Turn off power and pull out the power cable from the electrical outlet.

Using the plotter under these situations might cause electrical attack or fire by creepage.

Contact the salesman or Richpeace authorized agent to maintain it.

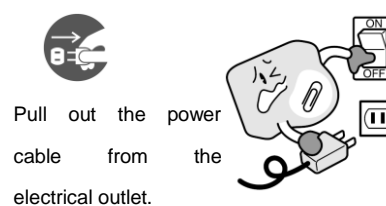

Don't pull it forcibly when you need to pull out the power wire or Cable.  
These actions might damage electrical wire and cause fire or electrical attack.



Forbidden

Don't try to append lube for the plotter.  
These actions might cause mechanical malfunction.

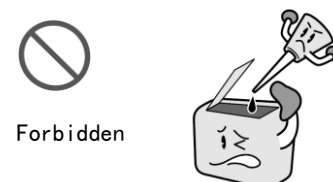

Forbidden

Don't use the thinner or gas to clear machine.  
These actions might weaken the capability of the plotter.

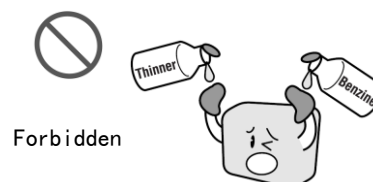

Forbidden

Make sure there is enough space for working, or else it might cause plotting error.  
If touch the machine, it might cause plotting error.

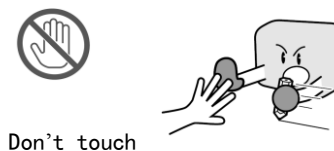

Don't touch

Use indoor daylight lamp or other electrical light, please make sure there is at least one meter distance between machine and light.

The distance too near might cause sensor malfunction,  
and can't measure the normal size of the medium.



You must move it slowly when you need to move the print head manually.  
Quick movement might damage the plotter.



## **Chapter1 Install Plotter**

**1.1 Check the accessory**

**1.2 Technical parameter**

**1.3 Structure and installation of new model plotter**

**1.4 Structure and installation**









**1.5 Structure and installation of MJ 135 plotter**

**1.6 Connect to computer**



## 1.1 Check accessory

Refer to the standard accessory list as follows, check and make sure there is not missing . If there has missing accessory, please contact the salesman or Richforever authorized local agent.

Power cable one piece	USB data cable one piece
	
Bolt M6*40,flat&spring washer 4 sets	Allen key M3, M5 one set
	
Ink box two pieces(four pieces for four heads)	Manual book 1
	
Guarantee card one piece	VCD
	



Whole machine includes parts as follows:	
Plotter head one set	Left & right stand each one set
Beam one set	Roll shaft and feed shaft each one set
Paper hold one set two pieces	Balance paper bar two pieces (MJ135 with one piece)
Bolt M6*20,4 pieces; bar 2 pieces(new model plotter)	Square bar 2 pieces(for MJ 135 plotter)
Cartridge holder one set	Induction bracket one set

## 1.2 Technical parameter

### Plotter technical parameter:

Type \ Function	RF-MJ135	RF-MJ180	RF-MJ200	RF-MJ220	RF-MJ300
Max paper width	140cm	185cm	205cm	225cm	305cm
Max plotting width	138cm	183cm	203cm	223cm	303cm
Max cartridges	2	2 or 4			
Receiving paper system	None	Automatic paper receiving			
Max paper weight	35 Kg				
Max plotting speed	72 square meters per hour(two cartridges),140 square meters per hour(four cartridges)				
Ink box type	HP51645A/B ink box				
Plot precision	0.025 mm				
Medium type	30-60g paper				
Communication	USB port, LAN port				
Motor type	Servo motor				
Data format	HPGL				
<b>Environmental conditions demand:</b>					
Power	AC220V (110V) / 50Hz ±10%				
Storage temperature	-20 °C ~ 50 °C				
Working temperature	0 °C ~ 40 °C				

- : We can adjust the power input between 220V and 110V a to the voltage of customer.

#### Main specialty:

- ◆ Easy to install & use.
- ◆ Special LAN cable port data connection make it easy to use
- ◆ Hp Inkjet head with Hp technology is easy to change
- ◆ Compatible with many other brands Garment CAD HP-GL files.
- ◆ Simplified structure to reduce mechanical stress and insure the easy maintenance
- ◆ Auto alarm when paper jams and uses out
- ◆ Servo motors make the plot high speed and working smoothly

### 1.3 Structure and installation of new model plotter

#### 1.3.1 Structure and parts functions

As following figure shows, compared with common model plotter, the difference is feeding system and receiving system are on same side, save space; low the roll motor near ground, it is more convenient to install paper. Add two pieces of bar back of plotter.

##### **Front**

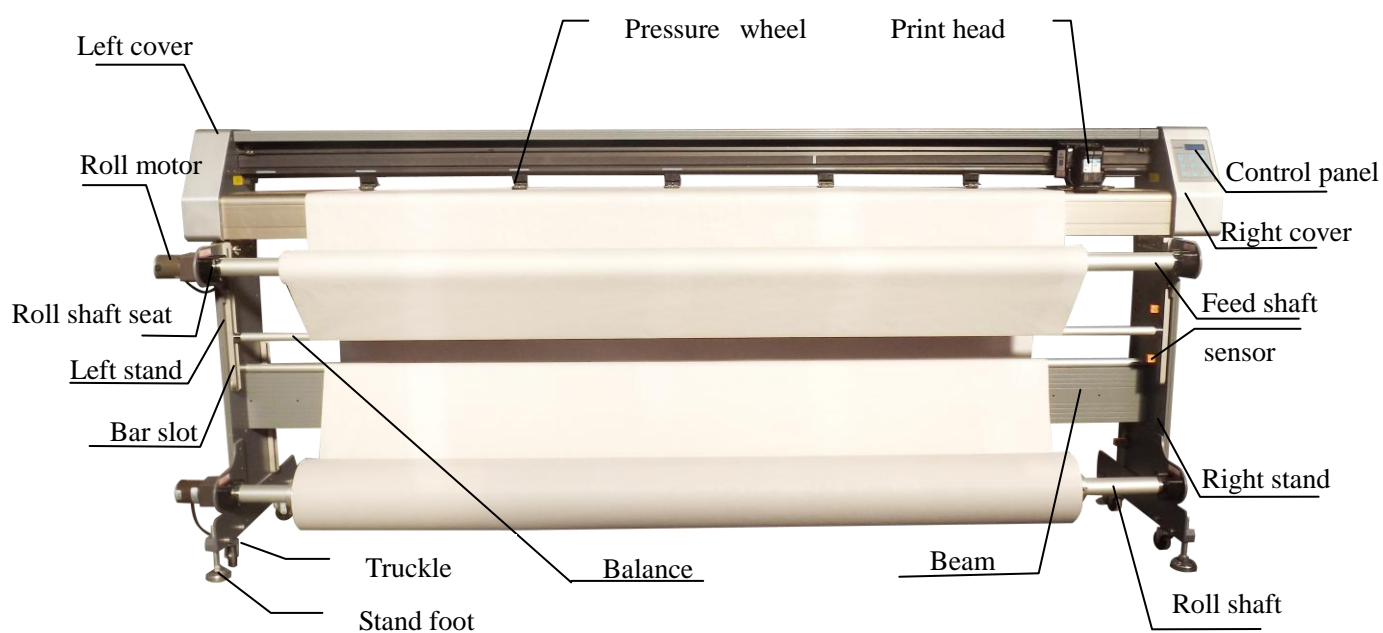

##### **Back**

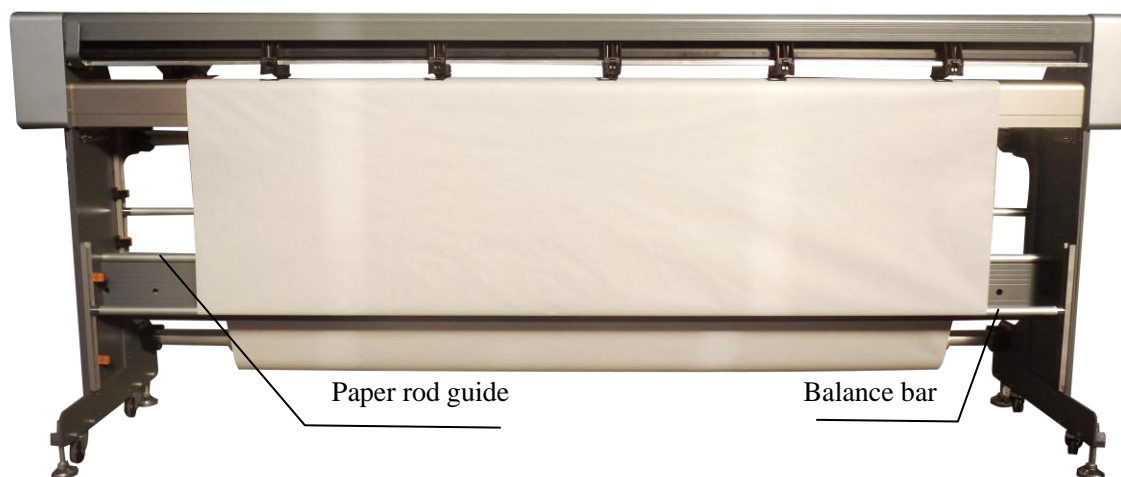

### 1.3.2 Installation

#### Stand configuration

Bottom stand:left stand、right stand、beam and bar.



#### Installation

1. Encase the spring washer and flat washer into the six-angle bolt. (See as follows)

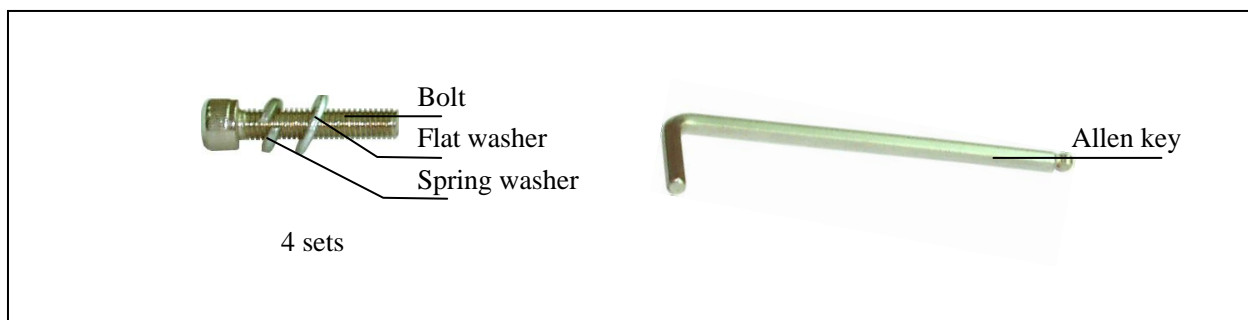

2. Lay down the four stand feet of the left and right stands to make it balanced.
3. Plug the bolts into the hole at right stand, fix the right stand with the beam by Allen key, and fasten the bolts. The left side is in the same way.

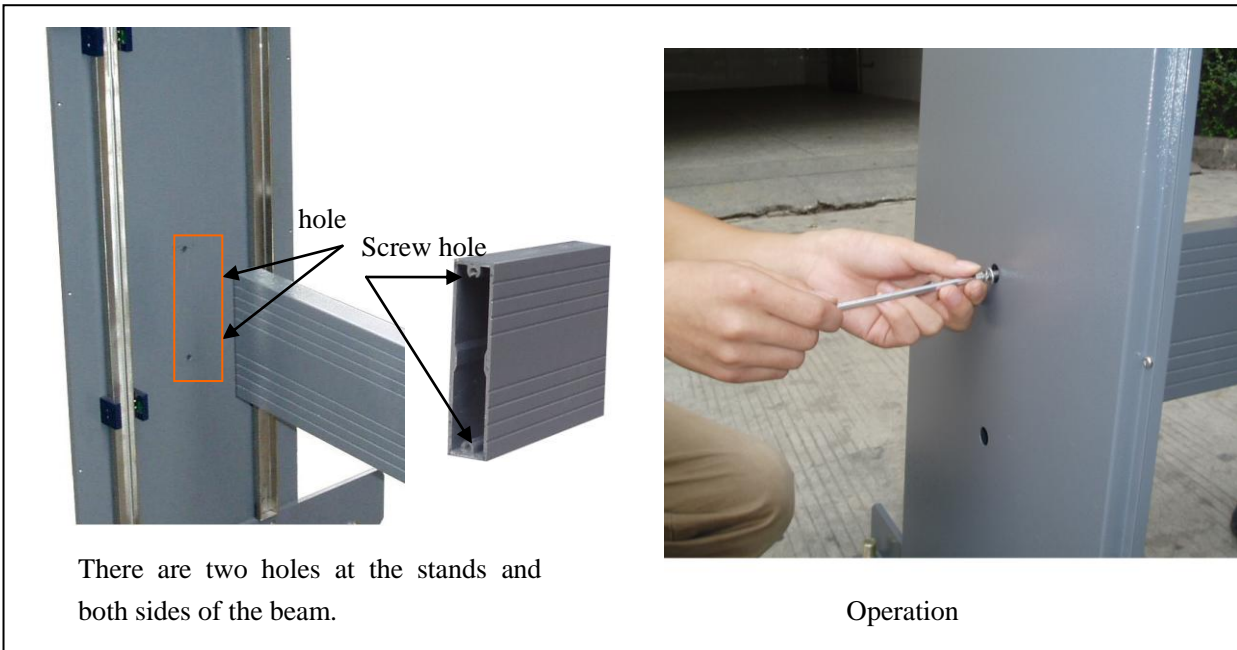

- After finishing the installation of the left and right stands, install the plotter head on the stand. Lift up the head, put it on the stand, plug the head angle iron notch on the stand bolts, fasten the butterfly screws after putting away the both sides of the head, and then fix the head on the stand. Please make sure there is no gap between the head and the stand.

**Whole plotter head**

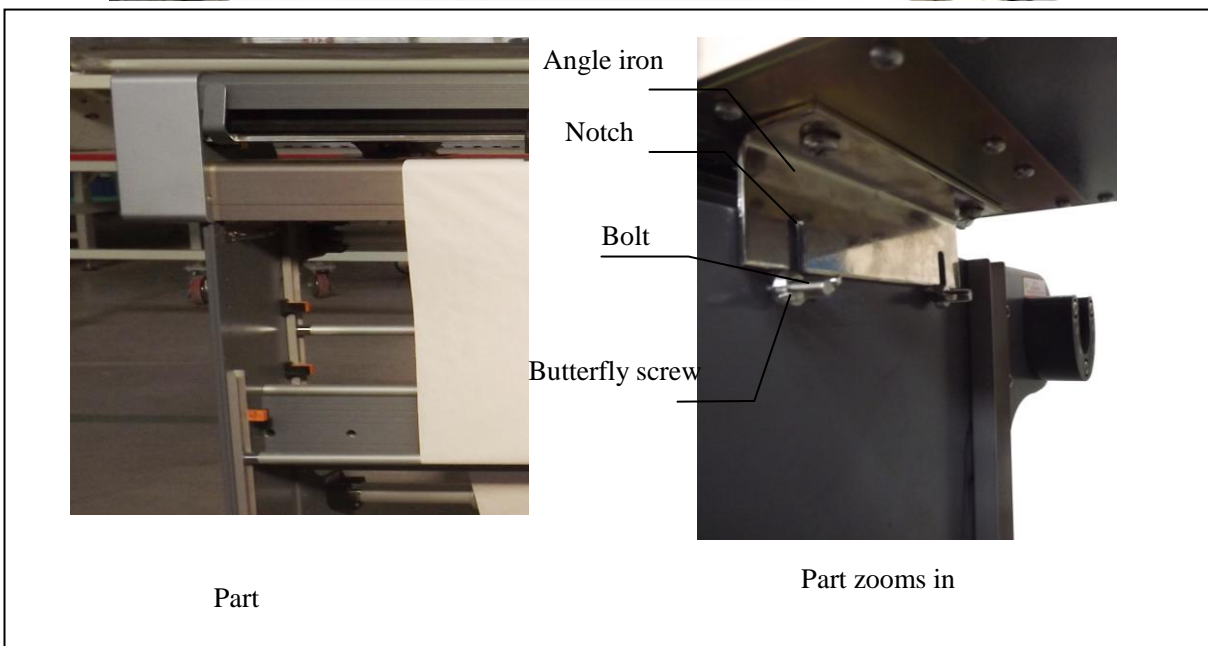

## 5. Connection

Plug the roll and feed motor cable at the left side into the aviation sockets. (Fig1)

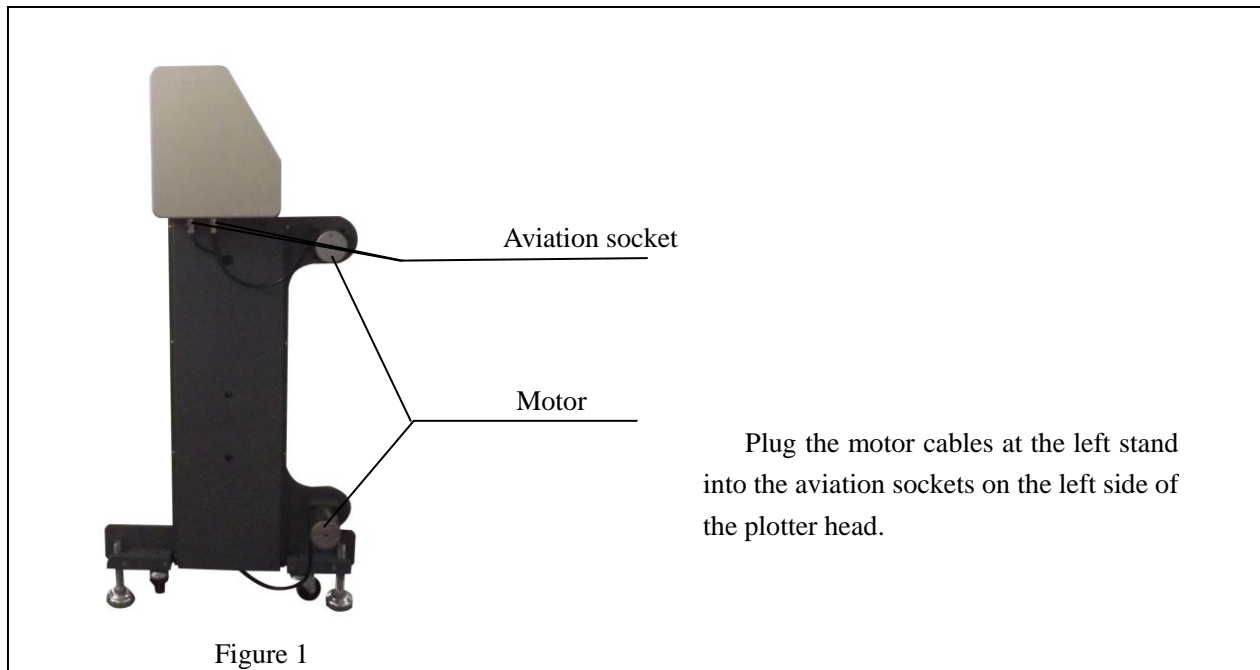

Plug the sensor cable at the right side into the aviation socket of the plotter. (Fig2)

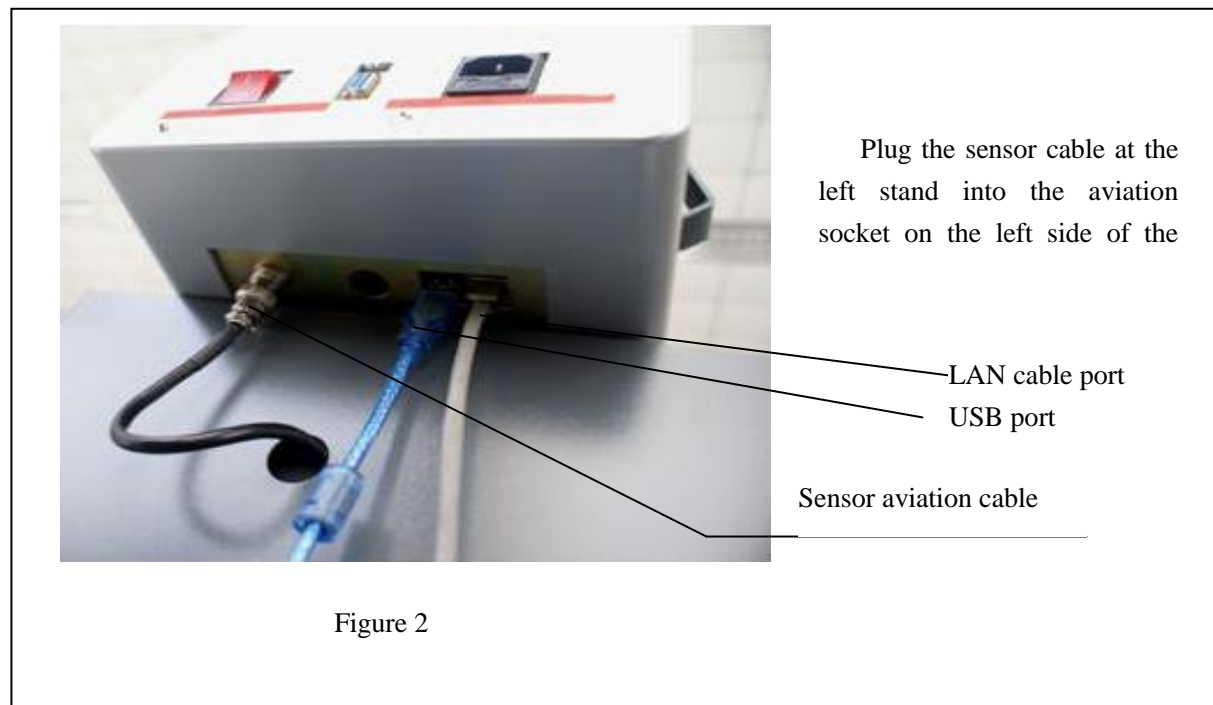

### 1.3.3 Install paper

1. Plunge paper feed shaft through the plotter paper roll, then fix the paper by fastening hubs on both sides of paper feed shaft

The dimension of installing paper as picture, please don't make the dimension oppositely.

Paper shaft

Feed shaft

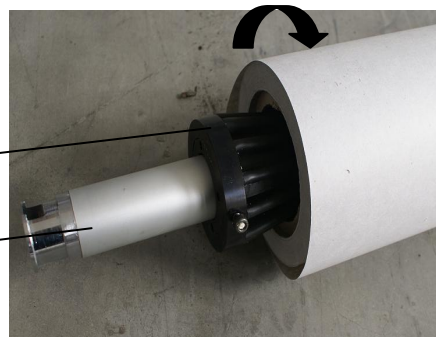

2. Put the paper roll on the feed shaft correctly, push fast paper hub into the core of paper roll, and then fasten them by rubber hammer.

Rubber hammer

Paper hub

Feed shaft



3. Fasten screws with Allen key; make sure the shaft and the paper roll have no opposite movement.

Allen key

Fasten screw

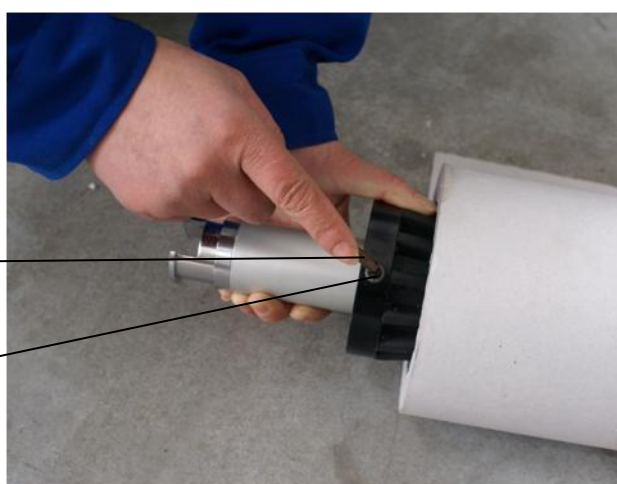

4. Lift up the feed shaft with paper roll, then put the right side of feed shaft into the right feed shaft seat (please following fig1), then put the left side of paper feed shaft into the feed shaft seat, please let the motor driver completely plunge into the left side of the Feed Shaft. (Please following fig2)



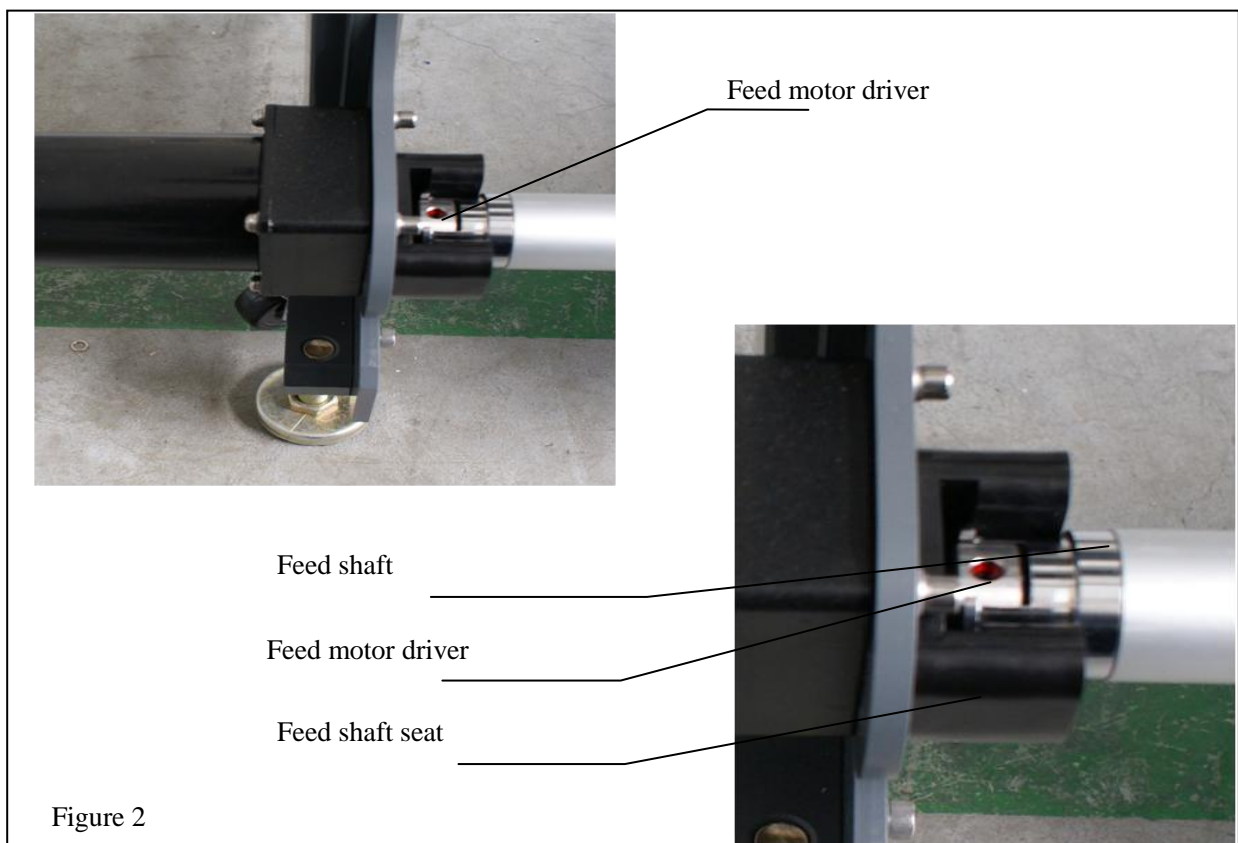
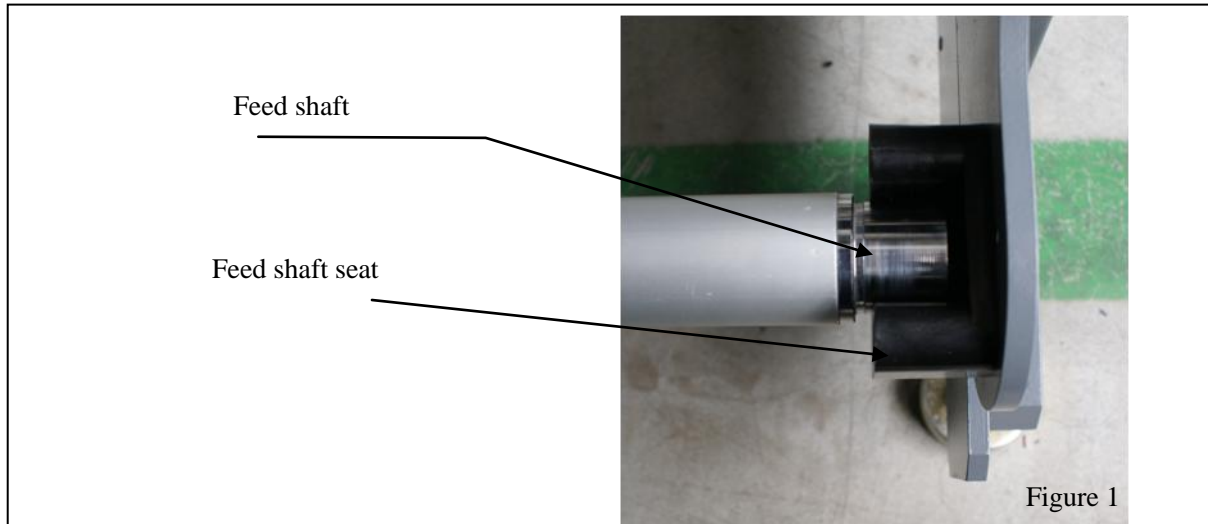

**Caution**

The max weight of paper roll is 35kg; it would damage motor if the paper roll is too heavy.

5. Please put the paper under pressure wheels, and put the paper through the plotter head after paper roll is installed on plotter correctly (please note to lift up the pressure wheels), then pull paper to the front of the plotter. Please follow the picture.

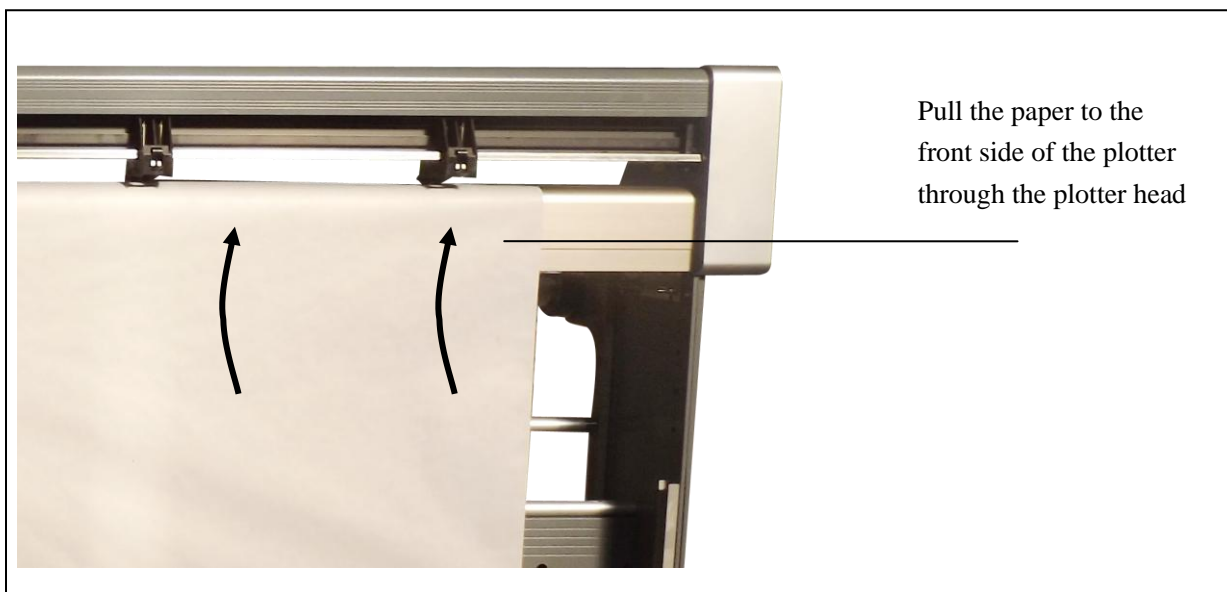

6. After pulling out the paper, please make the paper roll stillness, pull the paper evenly, make sure the pulling strength is the same on the both sides of paper and then stick the paper on the receive shaft from middle to both sides. We can stick the paper by 3-5 times, but the sticking times are different by different paper. (Please follow the picture as follows)
7. Rotate roll shaft manually for 5-8 circles.



From the middle to the other sides

8. Please lift up rotation pole by spanner, the pressure wheels and grinding wheels will press the paper tensely. (See as follows).

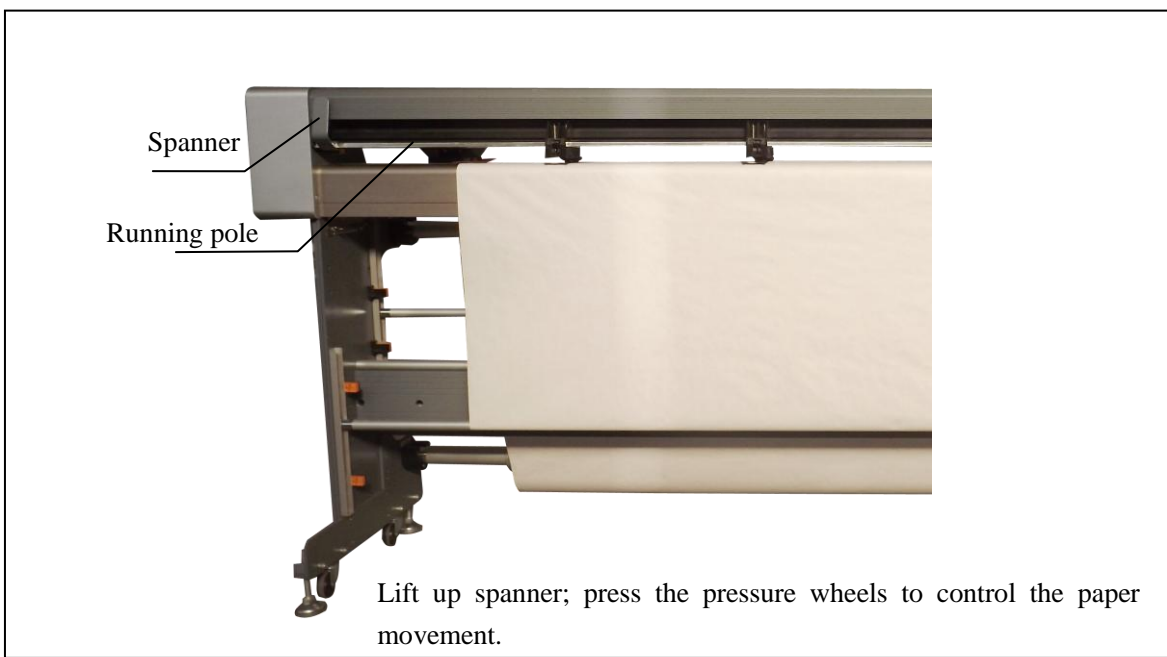

9. Please put the balance paper bars on paper and plug them into the balance paper bar slots on both sides. (See as follows)



10. Please rotate feed shaft and roll shaft to make balance paper bars between top and bottom sensors.  
**Installation of ink box is same for three model plotters.**

### 1.3.4 Paper cutting

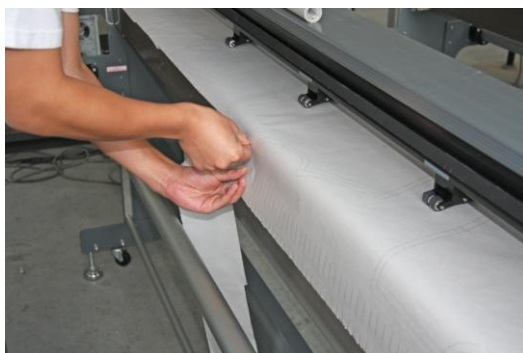

**Step one**



**Step two**



**Step three:** Press the number key adjust the best printing paper height

### 1.4 Structure and installation

At present, our company produces three kinds of plotters with different structure: common model (roll shaft and feed shaft are on different sides)、MJ135(without receiving system)、new model (roll shaft and feed shaft are on same side).

### 1.4.1 Structure and parts functions of common model

#### Face

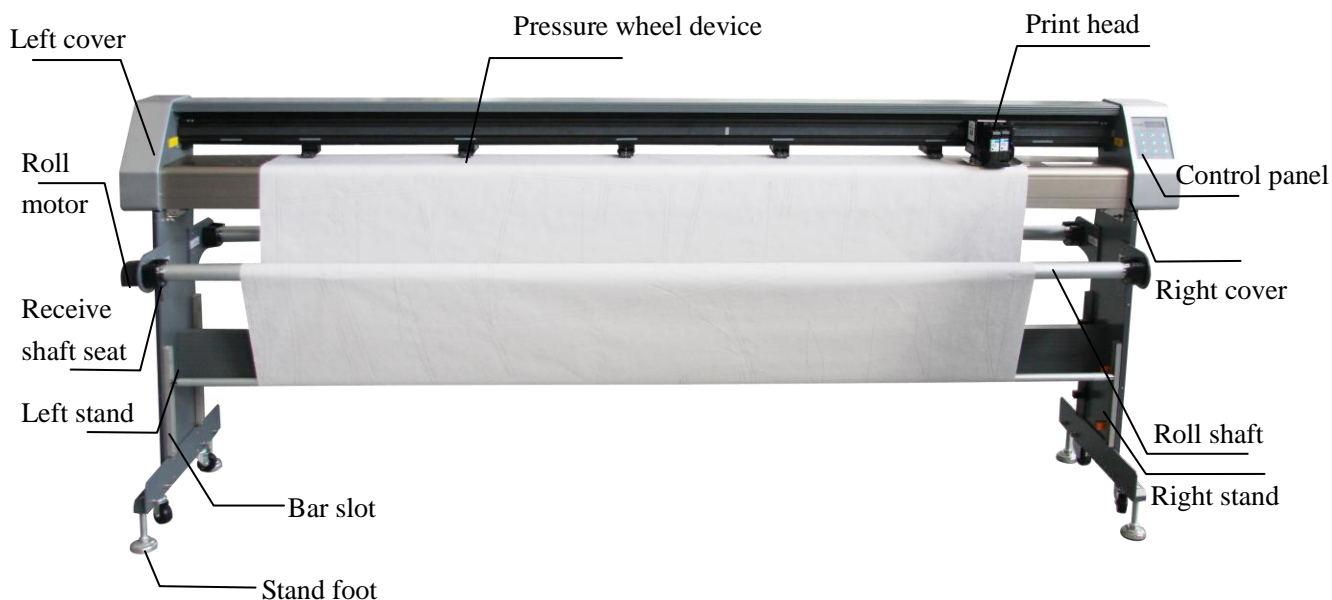

#### Pressure wheel device

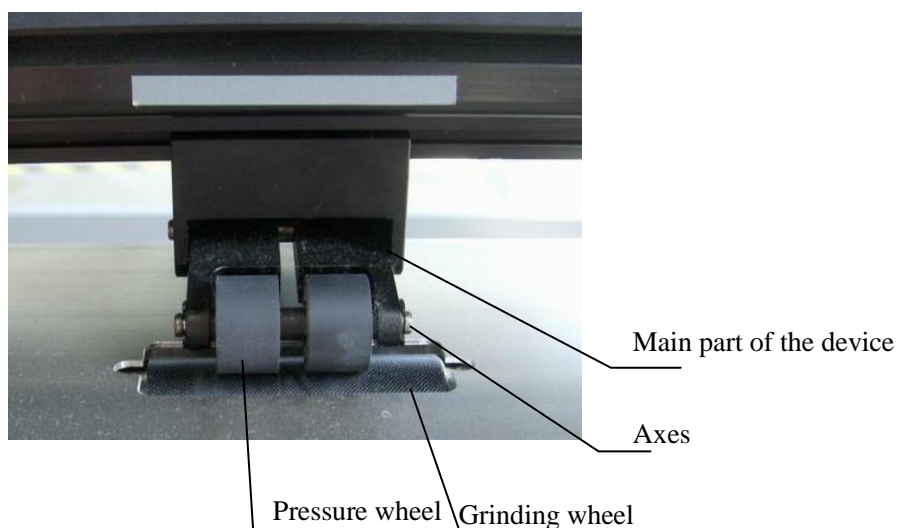

On the plotter, the paper movement of plotter is between pressure wheels and grinding wheels. Grinding wheels are fixed on the machine, and the wheels can move forwards and backwards. They cooperate to finish plotting. If the pressure wheels are not on grinding wheels, plotter paper will not move. At the time, please check whether the pressure wheels are under the green labels. Please make sure balance paper bars are between the two sensors before plotting.

 Note

- Please move the pressure wheels to proper site according to the plotter paper, and put them on the grinding wheels; otherwise it cannot plot normally or lacerate paper.
- Please lift up the pressure wheels when the plotter does not work to prolong the life of the plotter.
- Clean grinding wheels and pressure wheels regularly by toothbrush, never use the steel brush.

**Back**

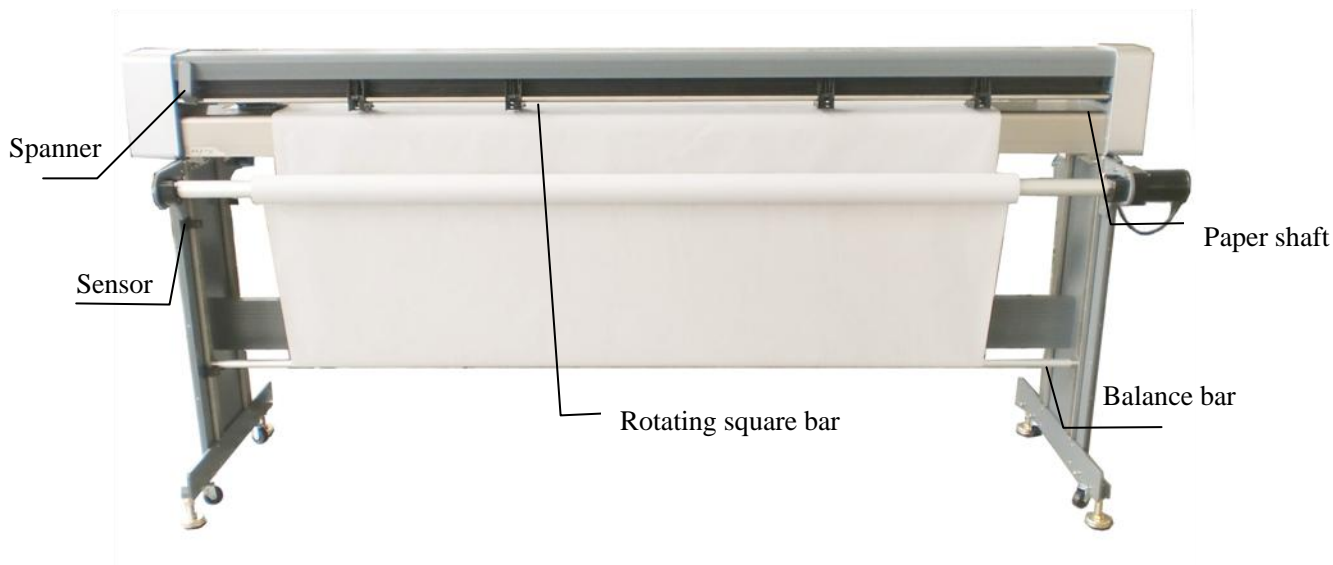
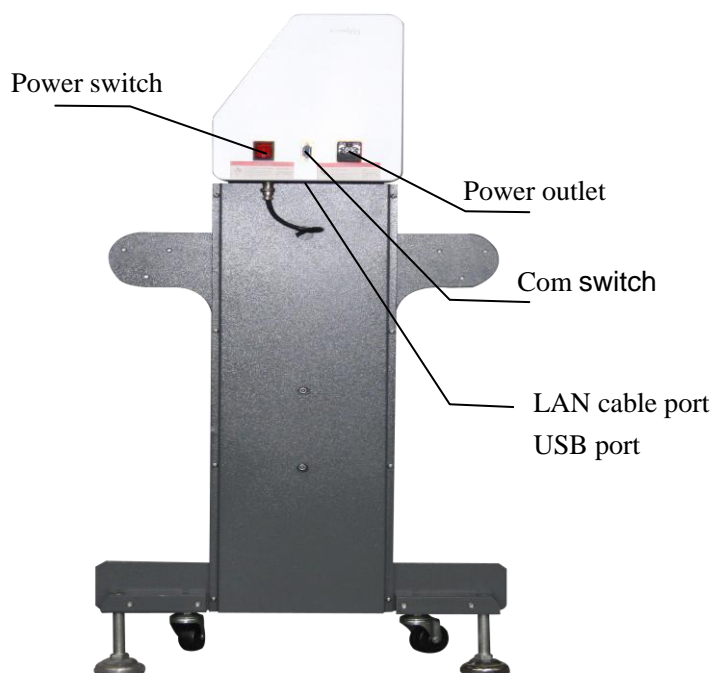

Table 1-1

Motor	Control receiving and feeding paper
Pressure wheel	Control paper moving when plotting
Print head	Drive ink boxes left/right when plotting
Spanner	Control the running pole to control the pressure wheels
Control panel	Operate the plotter and modify the settings
Sensor	Control the range of the balance paper bar
Bar slot	Control the range of the balance paper bar
Beam	Sustain the plotter

## Back



Power outlet: Connect power to the plotter  
 LAN cable port: Used to connect LAN cable  
 Power switch: used to turn on/off the plotter  
 USB port: Used to connect USB cable

## Control panel



2↑、8↓	Function: Use to modify the setting function in the LCD.
7   /▶	Function: Pause, Exit or enter into the function setup menu
4←、6→	Function: Use to modify the setting function in the LCD.
5 OK	Function: confirm the modifications that had been modified.
3、9	Function: It is used to set number likes other number key.
1 ≡	Function: used to enter into basic menu

## 1.4.2 Installation

### Stand configuration

Bottom stand: left stand, right stand and beam.



### Installation

1. Encase the spring washer and flat washer into the six-angle bolt. (See as follows)

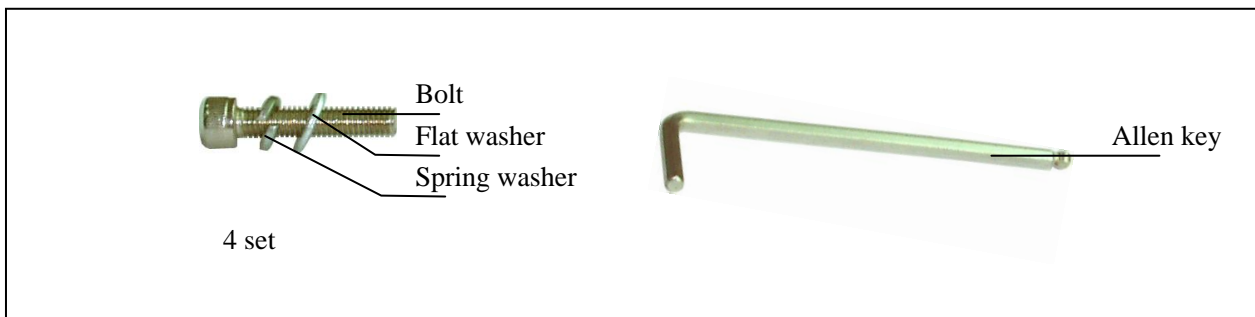

2. Lay down the four stand feet of the left and right stands to make it balanced.
3. Plug the bolts into the hole at right stand, fix the right stand with the beam by Allen key, and fasten the bolts. The left side is in the same way.



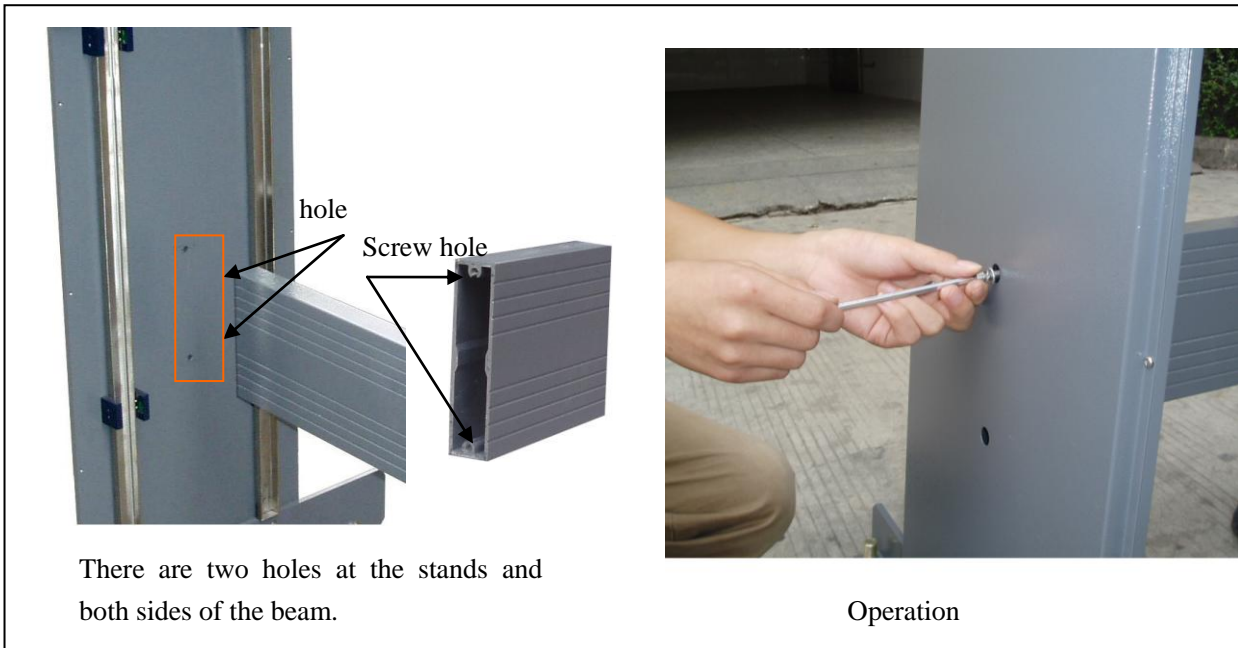

- After finishing the installation of the left and right stands, install the plotter head on the stand. Lift up the head, put it on the stand, plug the head angle iron notch on the stand bolts, fasten the butterfly screws after putting away the both sides of the head, and then fix the head on the stand. Please make sure there is no gap between the head and the stand.

**Whole plotter head**

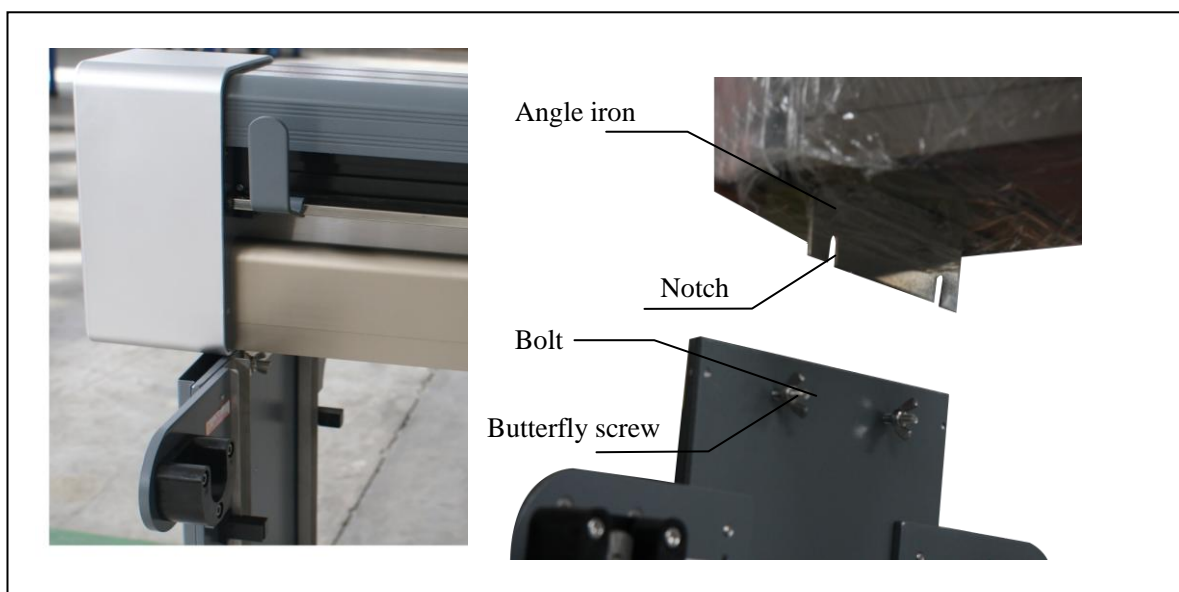

Part

Part zooms in

## 5.Connection

Plug the roll and feed motor cable at the left side into the aviation sockets.

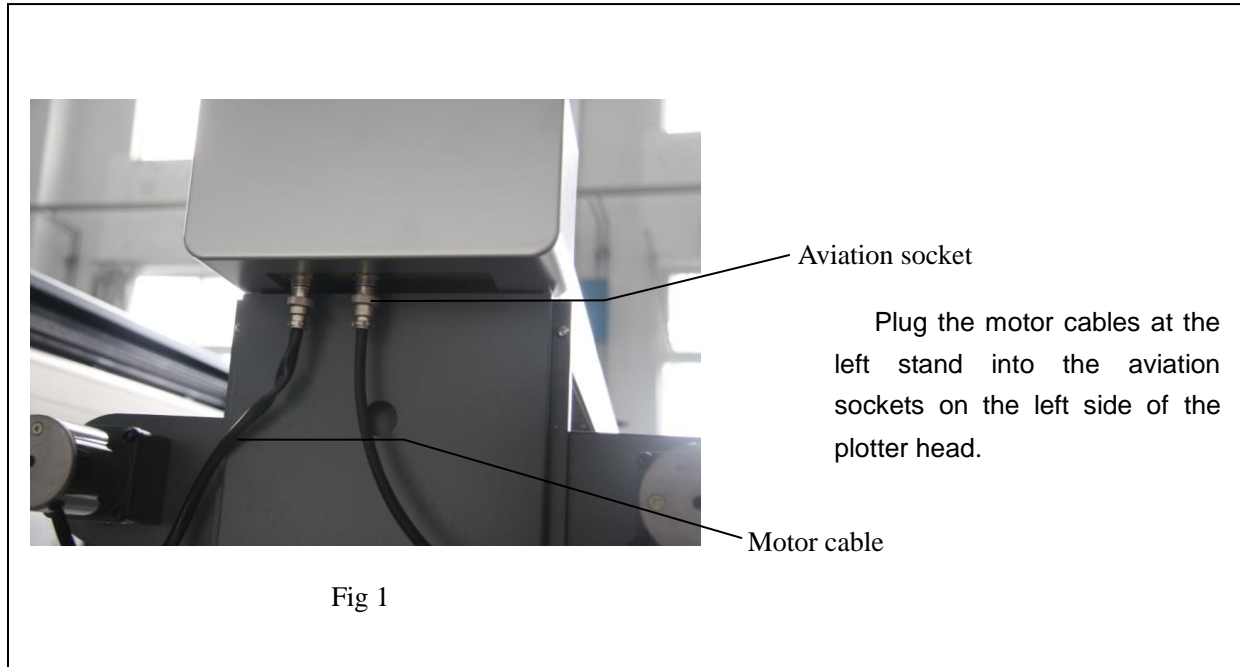

Plug the sensor cable at the right side into the aviation socket of the plotter. (Fig2)

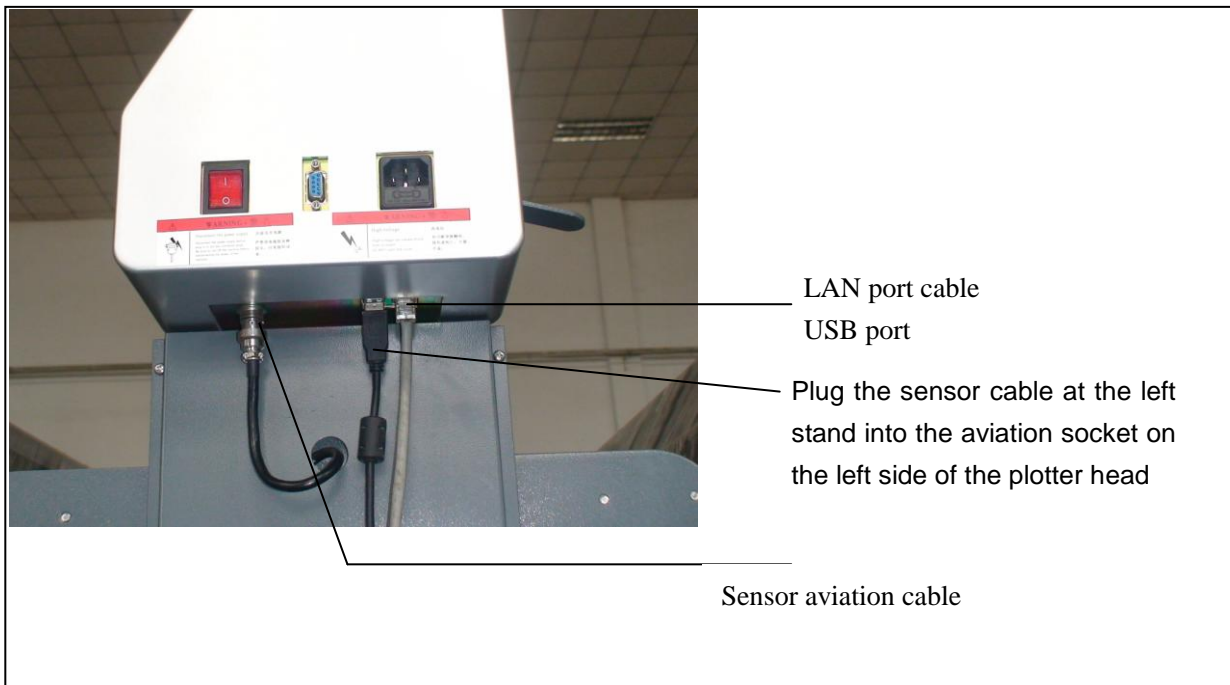

### 1.4.3 Install paper

1. Plunge paper feed shaft through the plotter paper roll, then fix the paper by fastening hubs on both sides of paper feed shaft.

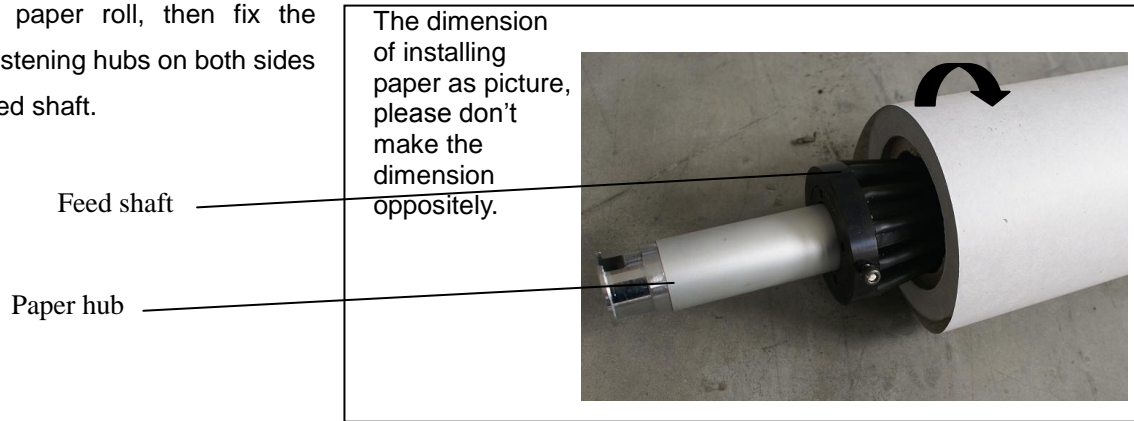

2. Put the paper roll on the feed shaft correctly, push fast paper hub into the core of paper roll, and then fasten them by rubber hammer.

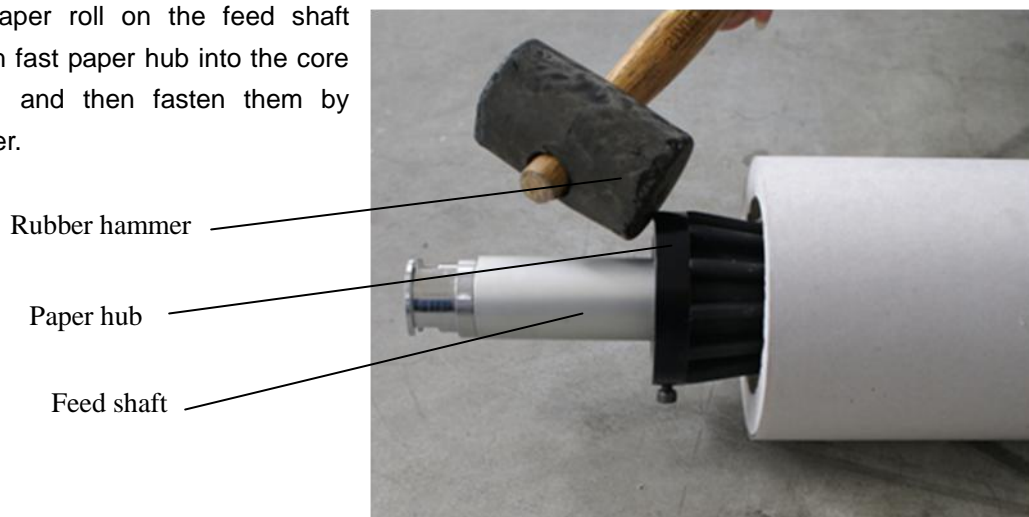

3. Fasten screws with Allen key; make sure the shaft and the paper roll have no opposite movement.

o

Allen key

Fasten screw

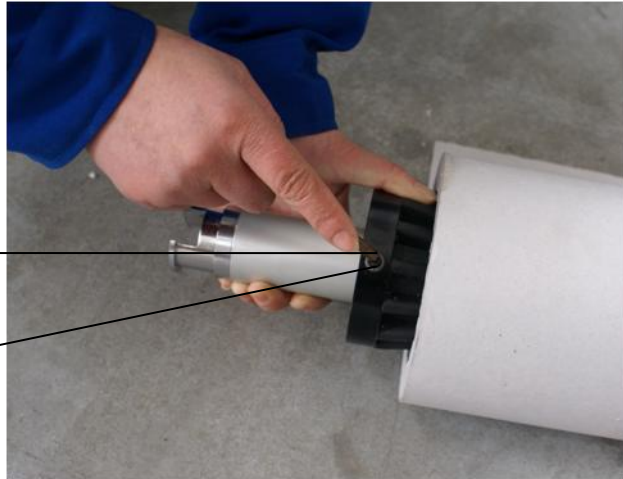

4. Lift up the feed shaft with paper roll, then put the left side of feed shaft into the left feed shaft seat (please following fig1), then put the right side of paper feed shaft into the feed shaft seat, please let the motor driver completely plunge into the right side of the Feed Shaft. (Please following fig2)

Feed shaft seat

Feed shaft

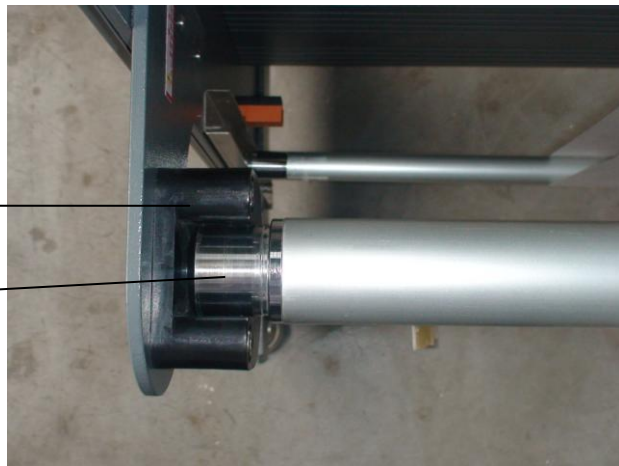
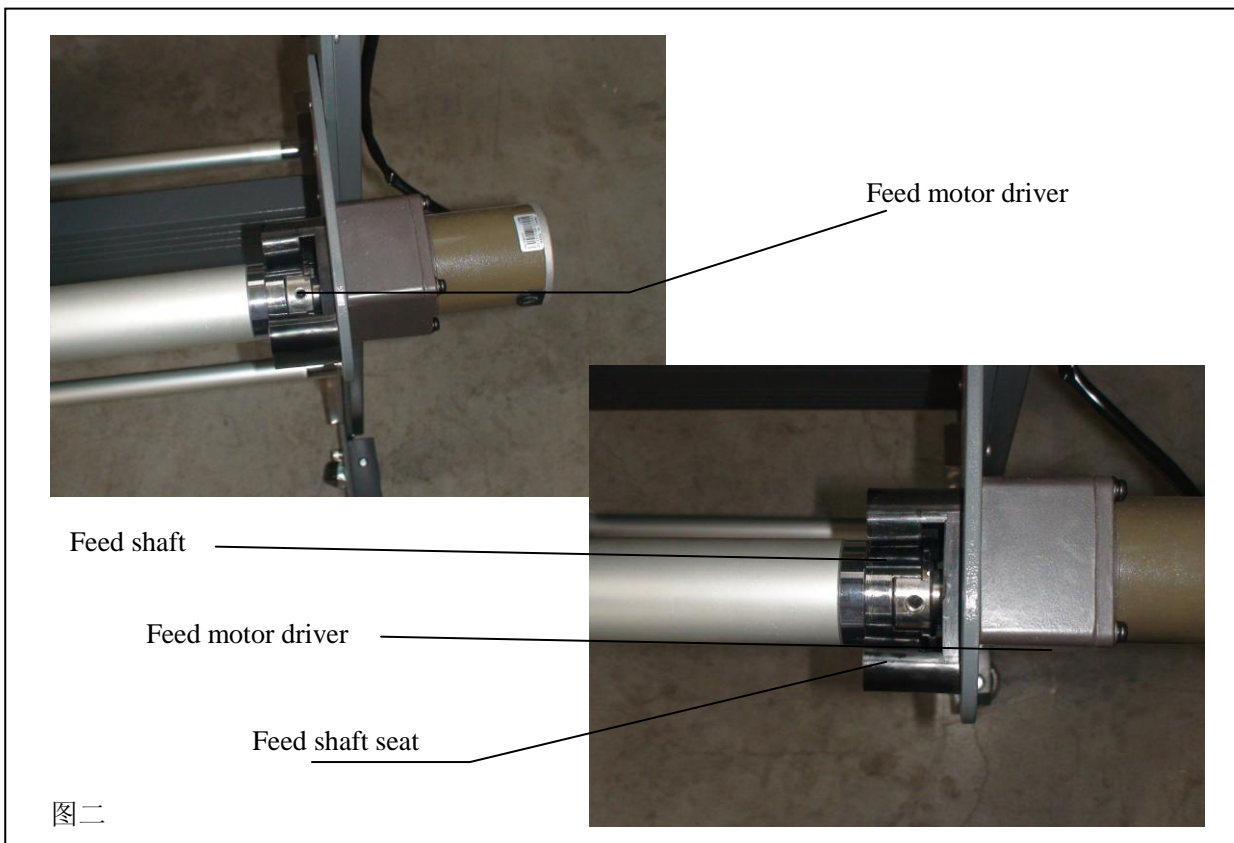

Fig1



**Caution**

The max weight of paper roll is 35kg; it would damage motor if the paper roll is too heavy.

5. Please put the paper under pressure wheels, and put the paper through the plotter head after paper roll is installed on plotter correctly (please note to lift up the pressure wheels), then pull paper to the front of the plotter. Please follow the picture.

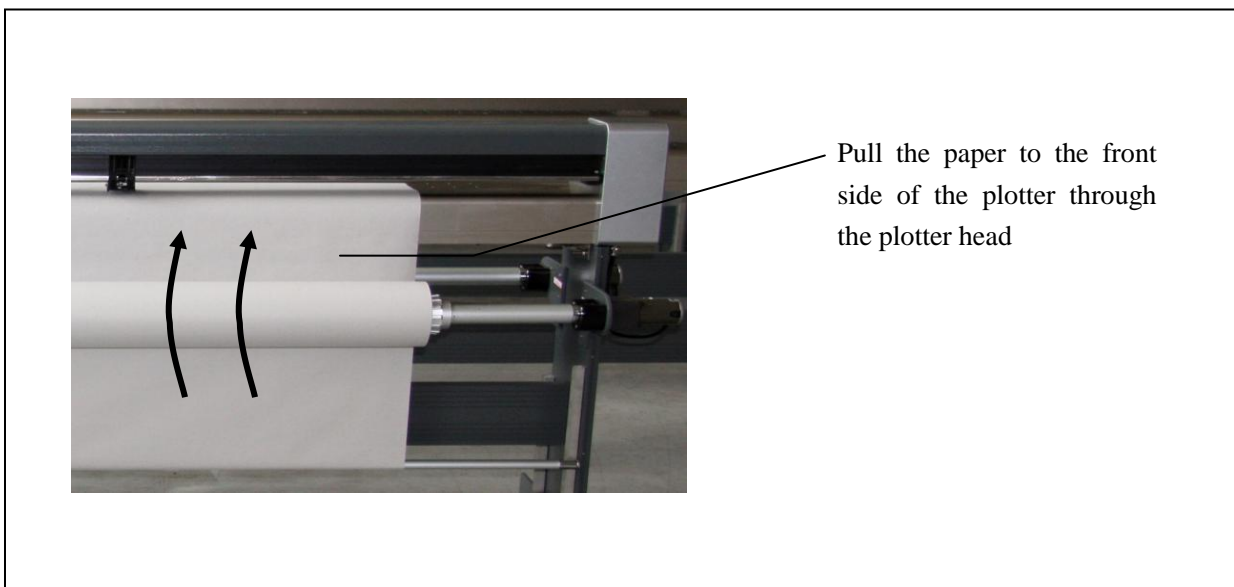

6. After pulling out the paper, please make the paper roll stillness, pull the paper evenly, make sure the pulling strength is the same on the both sides of paper and then stick the paper on the receive shaft from middle to both sides. We can stick the paper by 3-5 times, but the sticking times are different by different paper. (Please follow the picture as follows)
7. Rotate roll shaft manually for 5-8 circles.



**Caution:**

If the plotter model is RP-MJ135, due to there's no paper receiving system, so just need us put down the pressure wheels on the paper to finish installing the paper.



From the middle to the other sides

8. Please lift up rotation pole by spanner, the pressure wheels and grinding wheels will press the paper tensely. (See as follows).

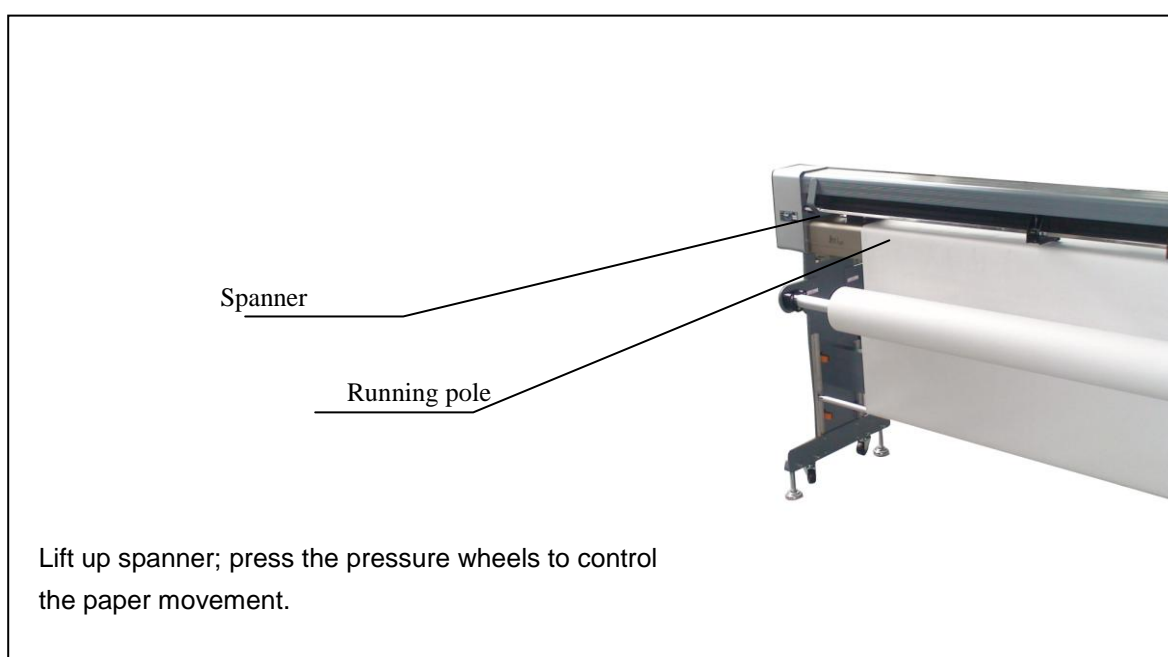

9. Please put the balance paper bars on paper and plug them into the balance paper bar slots on both sides.  
(See as follows)

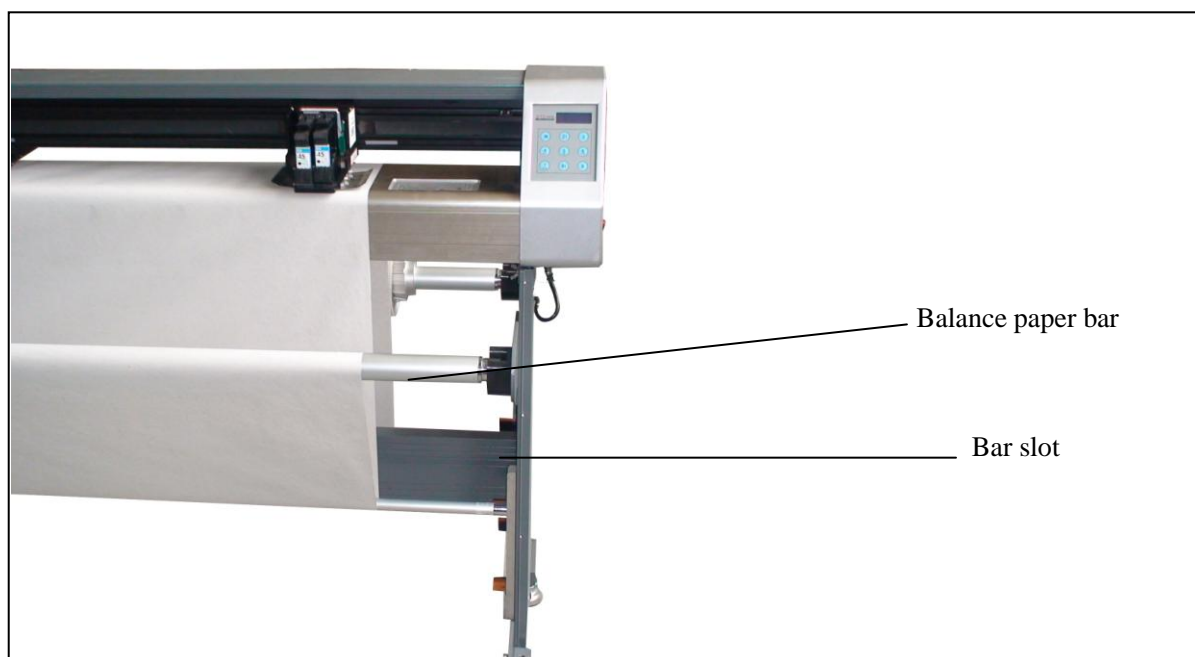

10. Please rotate feed shaft and roll shaft to make balance paper bars between top and bottom sensors.



#### 1.4.4 Install ink box

MJ inkjet plotter uses the model 51645A ink box; it can be bought at every Hp franchise, please use quality goods for good print quality.



**Step one**



**Step two**



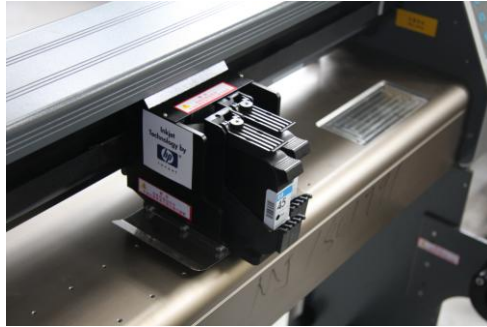

### Step three

Please install the ink box vertically into the print head, push the ink box to the bottom and the spanner of the print head.

You can check the left ink by looking the small window of the ink box, if there shows black that means no ink, you should change the ink box immediately, if there shows green, that means the ink is full.

## 1.5 Structure and installation of MJ135 plotter

### 1.5.1 Structure and parts functions

As following figure shows, model MJ 135 plotters don't have roll receiving system, paper plotted would fall into the cloth. This kind of plotters are usually used to make pattern.

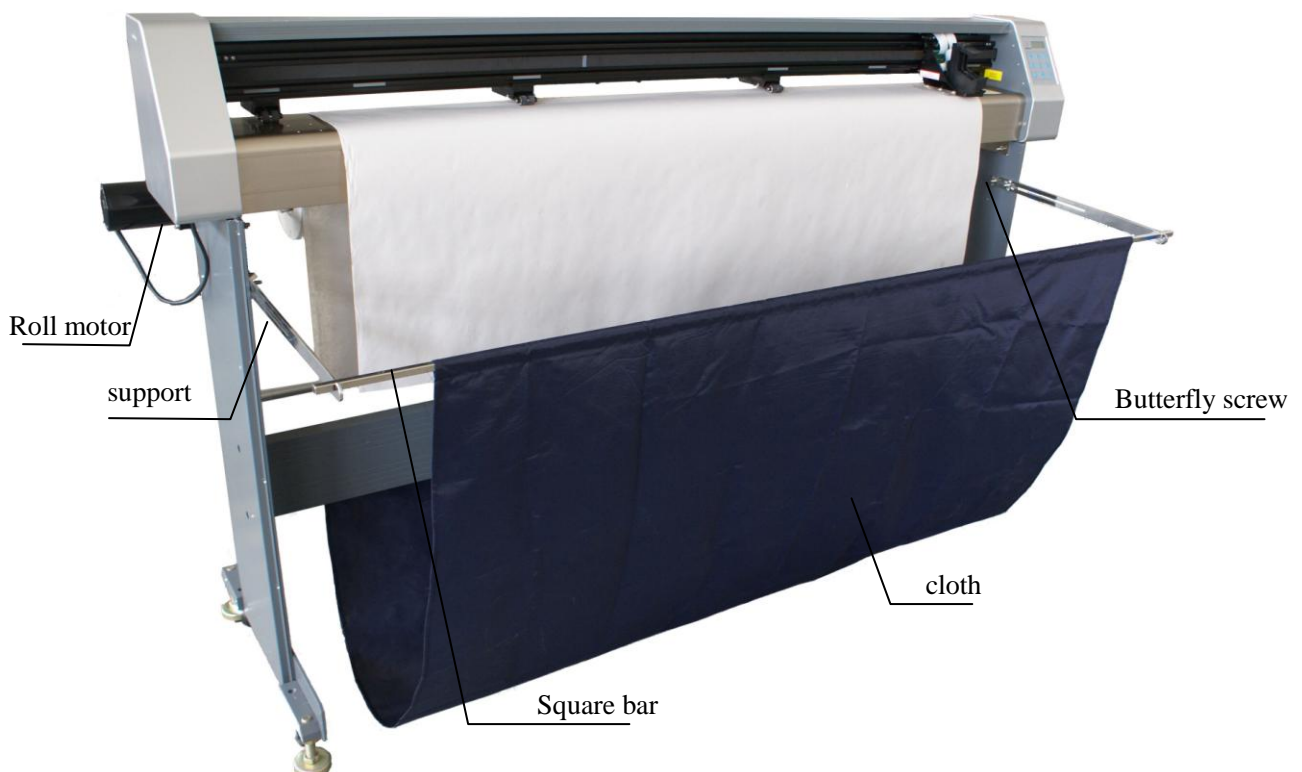



Table 1-2

Cloth	Collect paper plotted
Butterfly screw	Fasten support to stand
Support	Support square bar
Square bar	Support cloth

Functions of other parts please check table 1-1.

### 1.5.2 Installation

The installations of stand、head、ink box and paper for MJ 135plotter are as same as common model plotters, here we wouldn't repeat.

#### Install cloth

1. Take off butterfly screws, put support on as following figure, adjust the support to proper length according to your need, it is better make two supports same length, then fasten them to stands with butterfly screws.

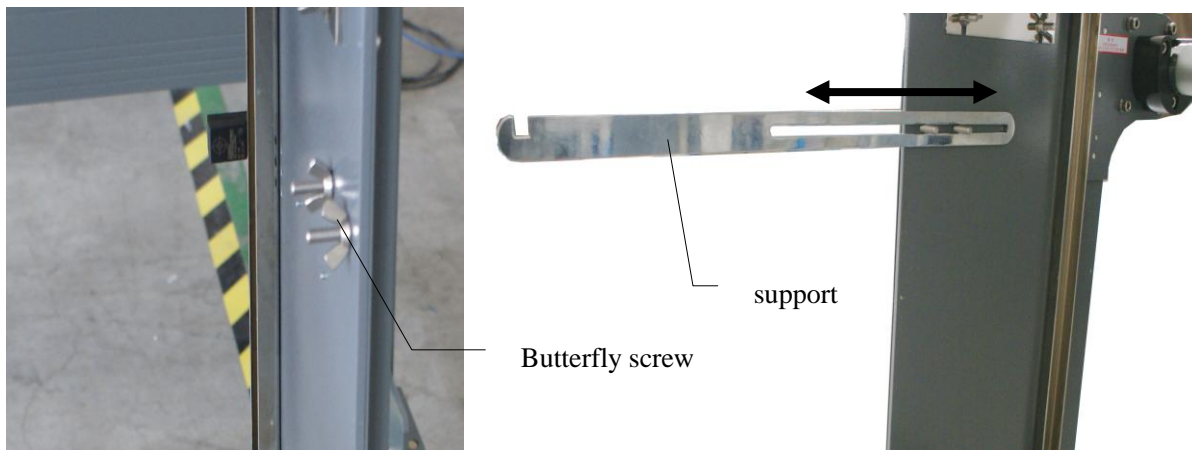

- Put two square bars through the two sides of cloth, put one piece of bar in notch that on the support, and put another bar in the bar seat behind the beam.

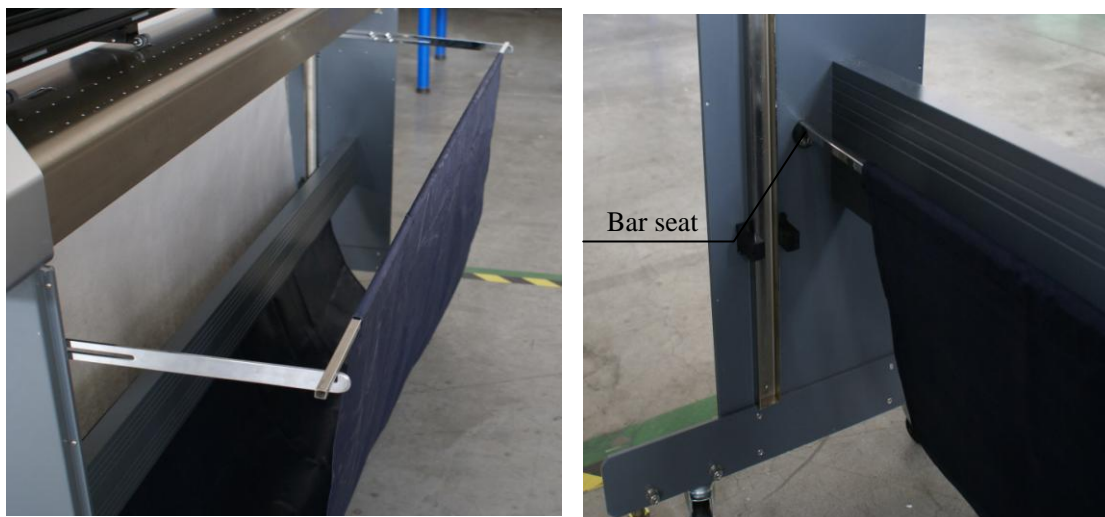

## 1.6 Connect to computer

- connect plotter to the computer by LAN cable  
the plotter is using the LAN cable port and USB port, you can connect the LAN cable to the computer or to the router, the LAN cable must be twist-pair.  
If the plotter connects to the router, the cable should be straight-through, made as follows:  
One side: white-orange/orange/white-green/blue/white-blue/green/white-brown/brown  
The other side: white-orange/orange/white-green/blue/white-blue/green/white-brown/brown



## **Chapter2 Basic setting and operation**

**2.1 Origin setting**

**2.2 Plot test graph**

**2.3 Delete file**

**2.4 Sensor check**

**2.5 Keyboard check**

**2.6 Collection start and stop**

**2.7 Print head cleaning times**

**2.8 Version info**

## 2.1 Origin setting

Origin is the start point when printing. Before printing, set the position of the origin up to the paper position. You must make sure the marker is totally inside the paper when setting the origin.

LCD displays:

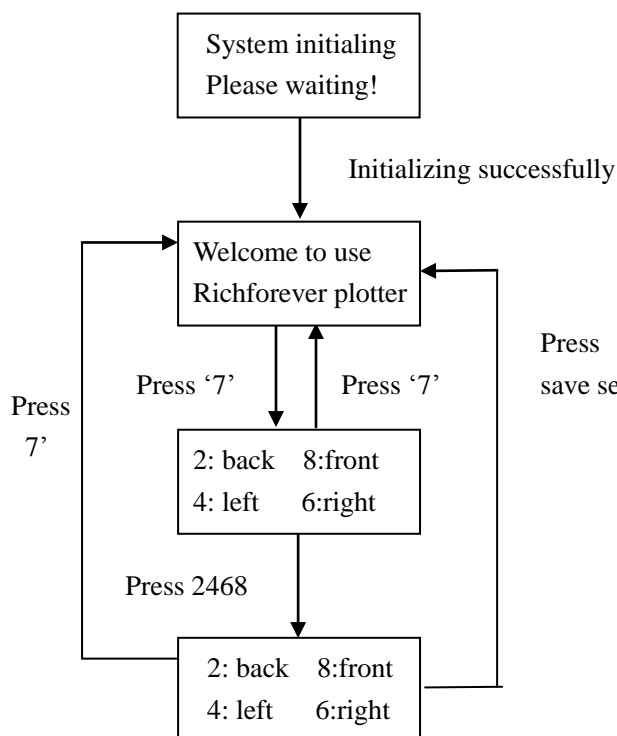

Operation process:

1. Turn on plotter, and it shows welcome to use enrich plotter.
2. Press '7' to pause the plotter. LCD displays to enter into the origin setting function.
3. Press '4' or '6' to move the print head left/right. Press '2' or '8' to move the paper front/back. Set the origin at the position that needed.
4. Press '5' to save the setting and turn back to main screen. Press '7' not save the setting and return to main screen. Press '1' to enter into the basic operation menu.



### Caution

- If the origin is not set correctly, it may cause the marker is not totally plot on the paper, if the origin position is too big, it may cause the width of the marker is bigger than the plotting width and can not plot.
- Never set the origin outside the paper.
- Don't modify the origin regularly after setting the correct origin.
- Never set the origin when plotting, it may cause the plotter dead or other abnormal status.
- We advise you set the origin to make sure the marker is in the middle of the paper for the best calibration.

## 2.2 Plot test graph

The function is for testing whether the ink box is jammed, so we can make sure whether need to change or clean the ink box.

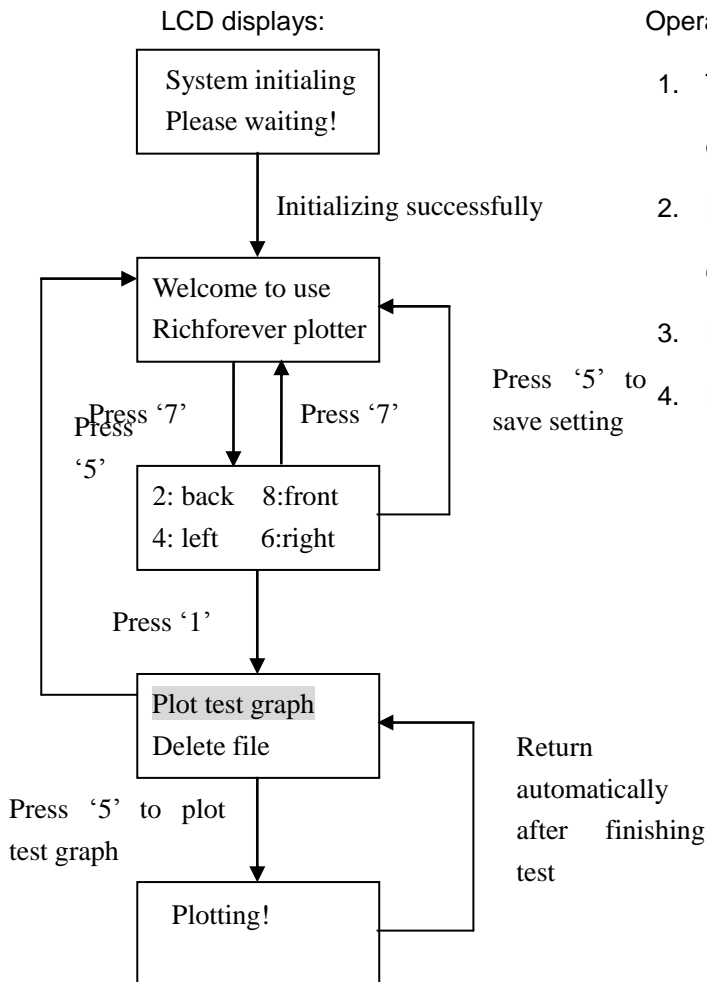

### Caution

Don't plot test graph when plotting.

## 2.3 Delete file

The function is for deleting the file that has been sent to the plotter by mistake.

LCD displays:

Operation process:

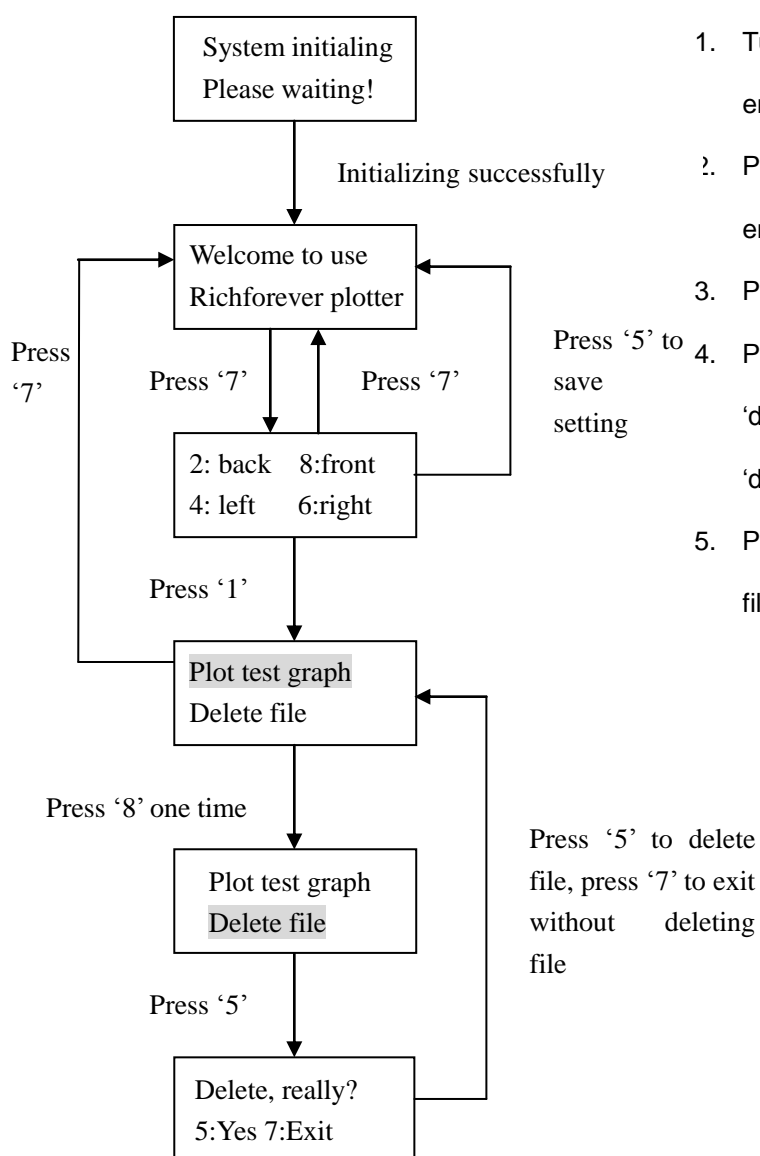

1. Turn on plotter, and it shows welcome to use enrich plotter.
2. Press '7' to pause the plotter. LCD displays to enter into the origin setting function.
3. Press '1' to enter into the basic menu.
4. Press '8' one time to choose the function 'delete file', press '5' to enter into the function 'delete file'.
5. Press '7' to exit, press '5' to delete the current file and return to the basic menu.



### Caution

The deleted file will be deleted from the plotcenter and the next file in the plotcenter will be paused.



## 2.4 Sensor check

The function is used to check whether all the sensors are working, when one sensor is blocked, the screen will show the name of the sensor, and only one sensor can be checked at one time, if the sensor is damaged, the screen shows nothing.

LCD displays:

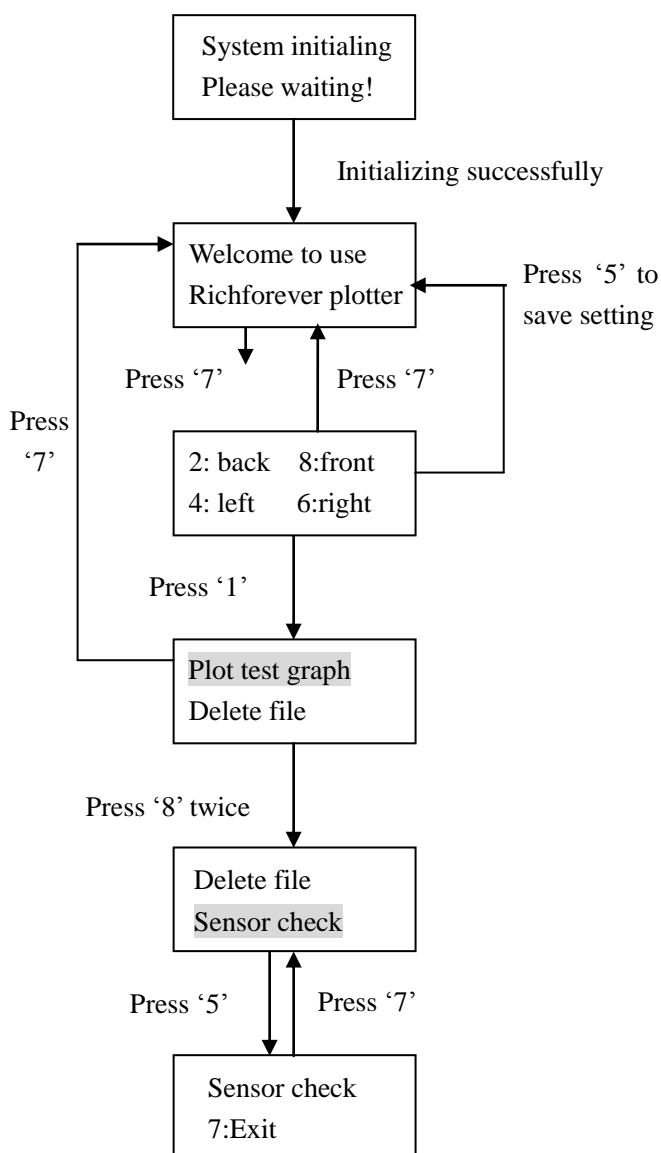

Operation process:

1. Turn on plotter, and it shows welcome to use enrich plotter.
2. Press '7' to pause the plotter. LCD displays to enter into the origin setting function.
3. Press '1' to enter into the basic menu. Press '8' twice to choose the function 'Sensor check', press '5' to enter into the function.
4. Blocking the top sensor of the roll shaft side, screen shows 'roll paper over', the bottom sensor of the roll shaft side, screen shows 'roll paper start', the top sensor of the feed shaft side, screen shows 'feed paper start', the top sensor of the feed shaft side, screen shows 'feed paper stop'.
5. Press '7' to exit.

## 2.5 Keyboard check

The function is for checking every key's correctness; you must check all the nine keys.

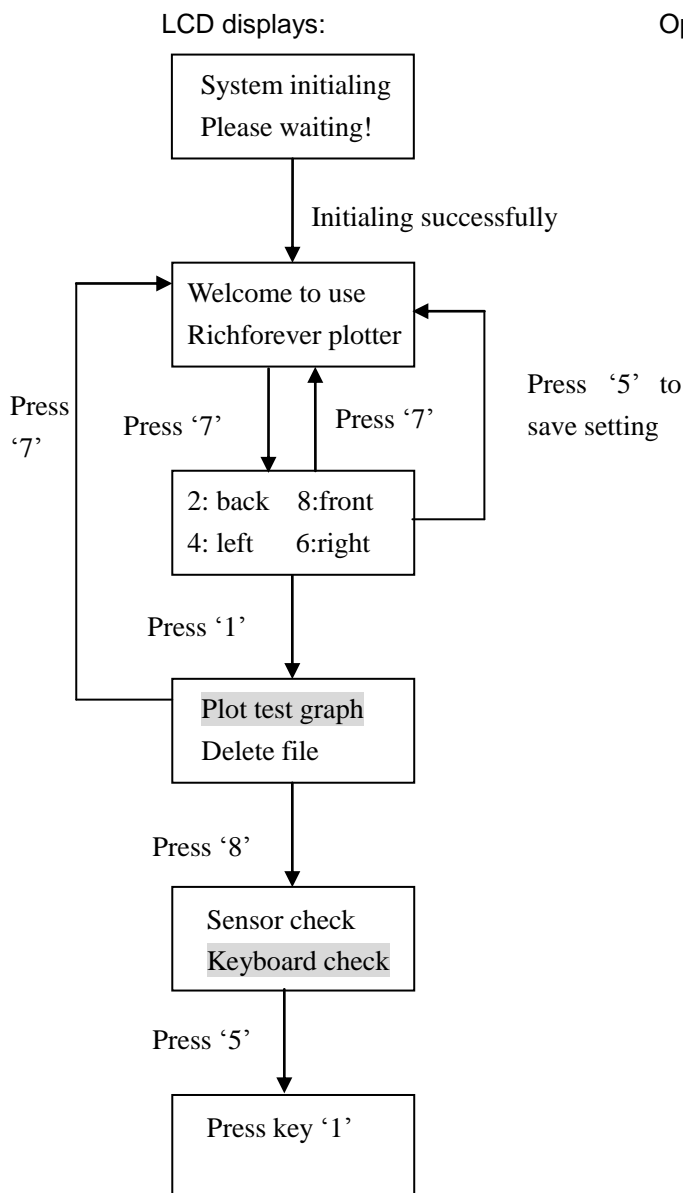

## 2.6 Collection start and stop

This function is mainly to control motor collect paper and back paper.

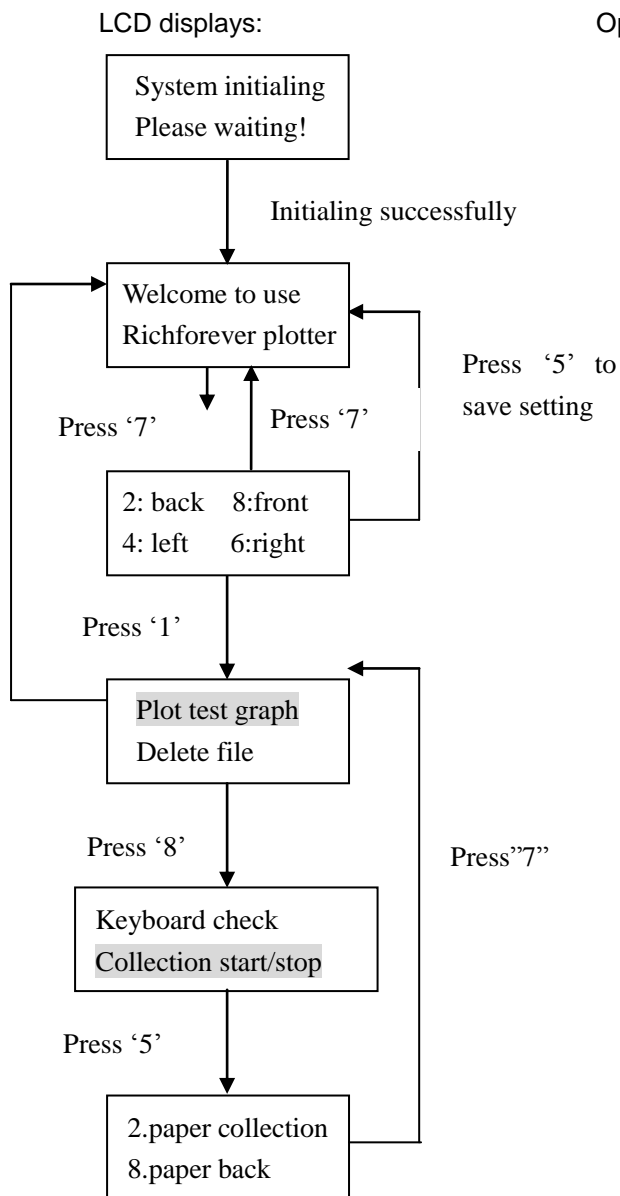

Operation process:

1. Turn on plotter, and it shows welcome to use enrich plotter.
2. Press '7' to pause the plotter. LCD displays to enter into the origin setting function.
3. Press '1' to enter into the basic menu.
4. Press '8' to choose the function 'collection start and stop'.
5. Press '5' to enter into the function.
6. Press '2' paper collection, press any key stop paper collection.
7. Press '8' paper back, press any key stop paper collection.
8. Motor stop, press "7" back to the basic menu.

## 2.7 Print head cleaning times

The function used before the settings file printed, print head cleaning times, setting range "1`5"

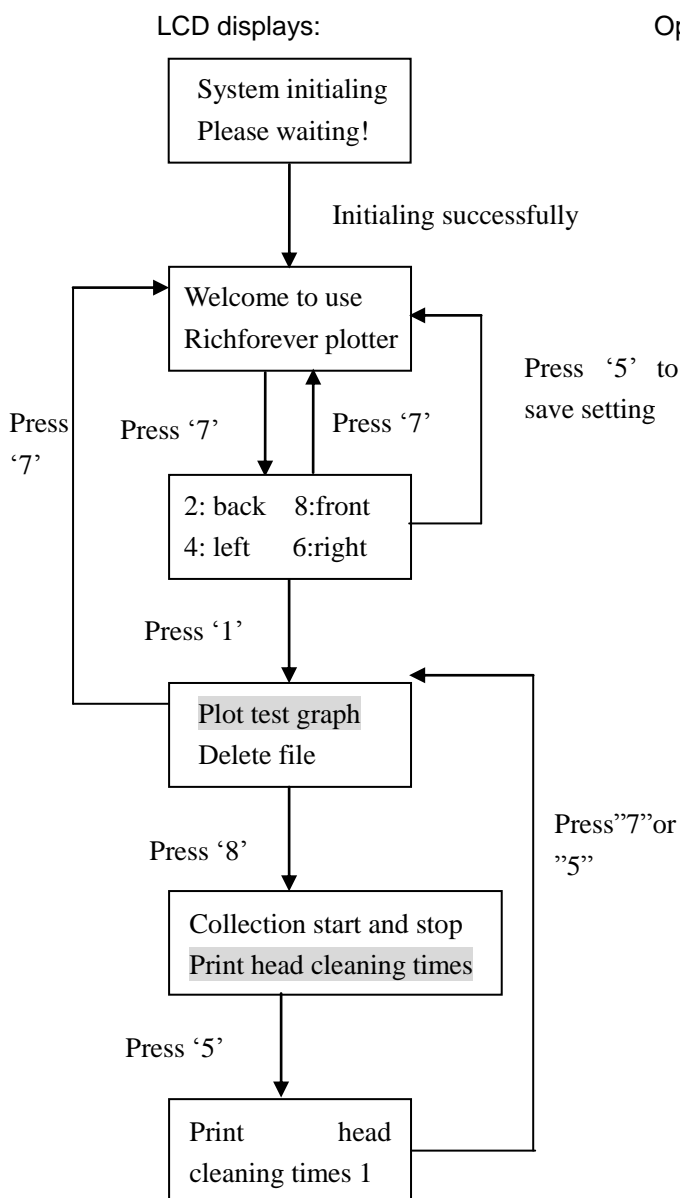

Operation process:

1. Turn on plotter, and it shows welcome to use enrich plotter.
2. Press '7' to pause the plotter. LCD displays to enter into the origin setting function.
3. Press '1' to enter into the basic menu.
4. Press '8' to choose the function 'Print head cleaning times'.
5. Press '5' to enter into the function.
6. Press '2' the number add 1.
7. Press '8' the number decrease 1.
8. Press '5' keep the revised number and exit.
9. Press '7' back to the basic menu and not save the revised number.

## 2.8 Version Info

The function only shows the version number and the data, it can't be modified.

LCD displays:

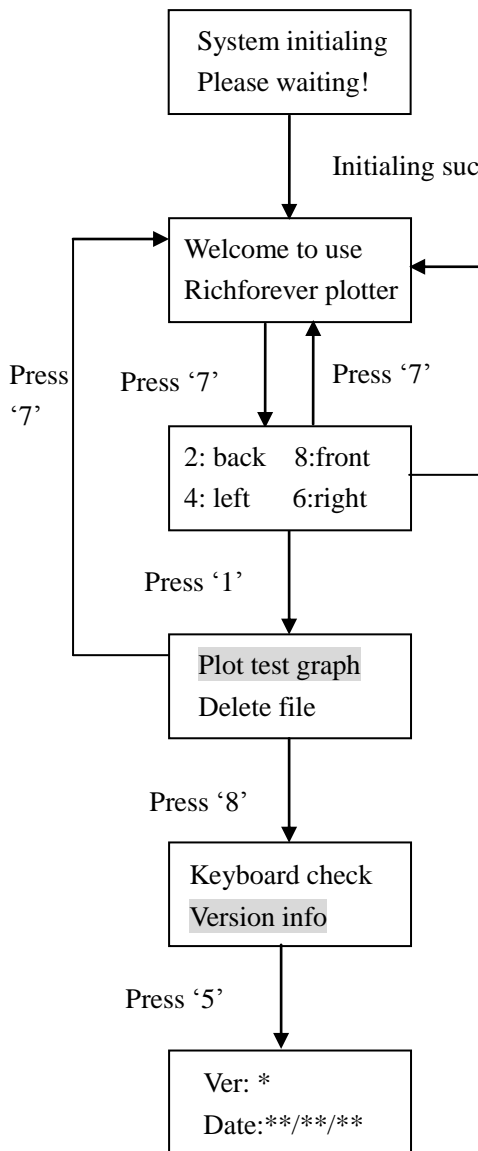

Operation process:

1. Turn on plotter, and it shows welcome to use enrich plotter.
  2. Press '7' to pause the plotter. LCD displays to enter into the origin setting function.
  3. Press '1' to enter into the basic menu.
  4. Press '8' four times to choose the function 'version info'.
  5. Press '5' to enter into the function.
  6. Press '7' to exit.
- Press '5' to save setting

## **Chapter3 Plot**

**3.1 Plotcenter**

**3.2 File**

**3.3 Tools**

**3.4 Language**

**3.5 Setup**

**3.6 Calibration**

**3.7 Plot sequence**

**3.8 Print preview**

**3.9 Operations after plotting**

### 3.1 Plotcenter

The plotcenter is only used for Richpeace plotter, the figure of the plotcenter as follows:

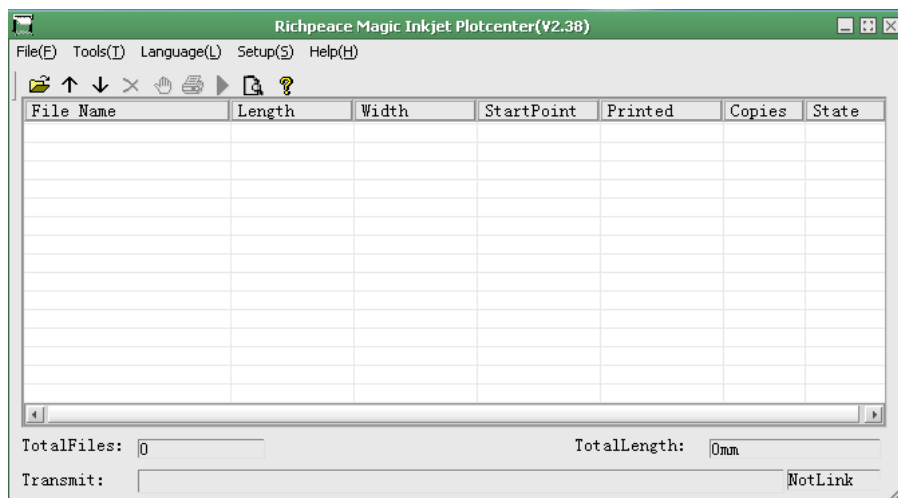

Please modify the calibration of the plotter when installing the machine and make sure the output measures are no problem.

It can be modified in the plotcenter to modify the calibration of the HPGL file, please refer to '3.6 Calibration'.

### 3.2 File

#### 1. Link

If the plotcenter can connect to the plotter, it will show connect successfully. If the IP is not set correct, it will appear the following dialog box. If the TCP/IP is set correct, the plotcenter will connect to the plotter automatically when open it. The link option will show the gray colour.

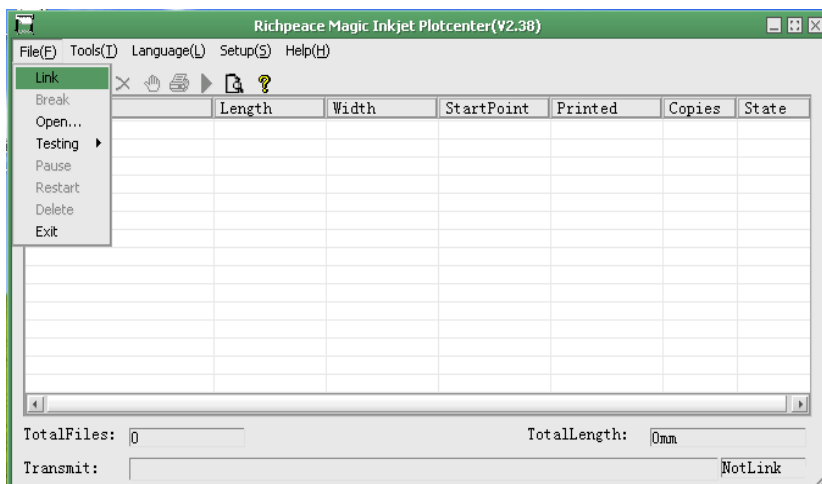

#### 2. Break

It is for disconnect the connection between the computer and the plotter.

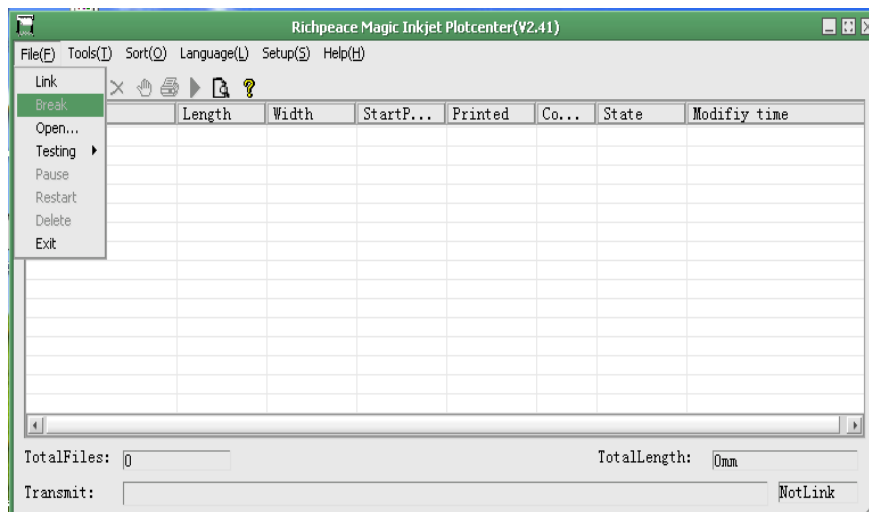

### 3. Open

Open the HPGL file you want to plot.

Operation process as follows:

- (1) Click the 'open' menu in the plot menu:

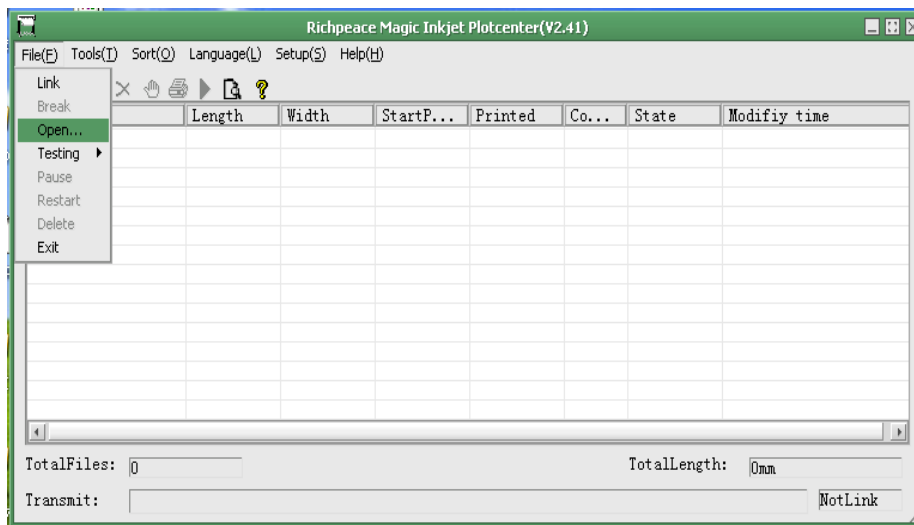

- (2) Popup 'open' dialogue, choose the needed files:



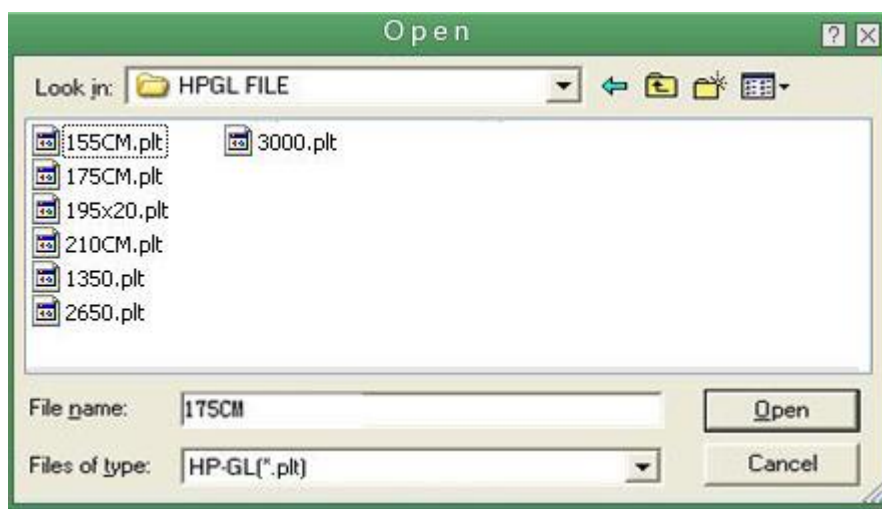

(3) . Click 'open', popup a window as follows:

Start point: you can input the value then plotter will start plotting from the value position.

Copies: input the value to set the plotting times.

Plot: click plot to start plotting.

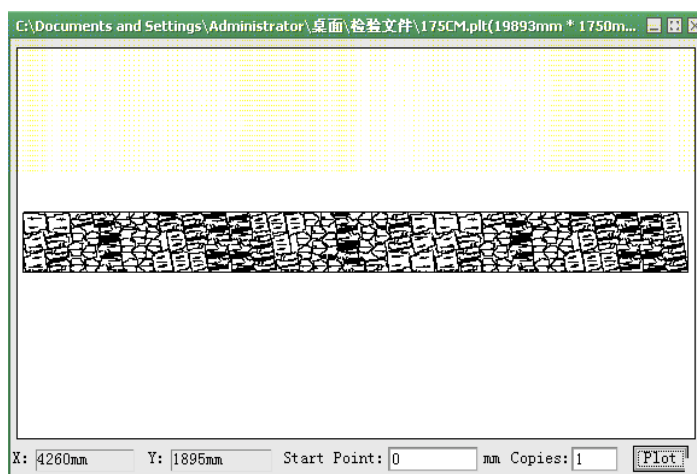

For example the plotting is suddenly stopped because of the plotter power is off, then we don't need to plot the total marker again, only need to click 'exit' and save the current plotting file, when you restart the plotter and turn on the plotcenter, there will be a reminder as follows: Then you can click ok to continue plotting at the stopped position.

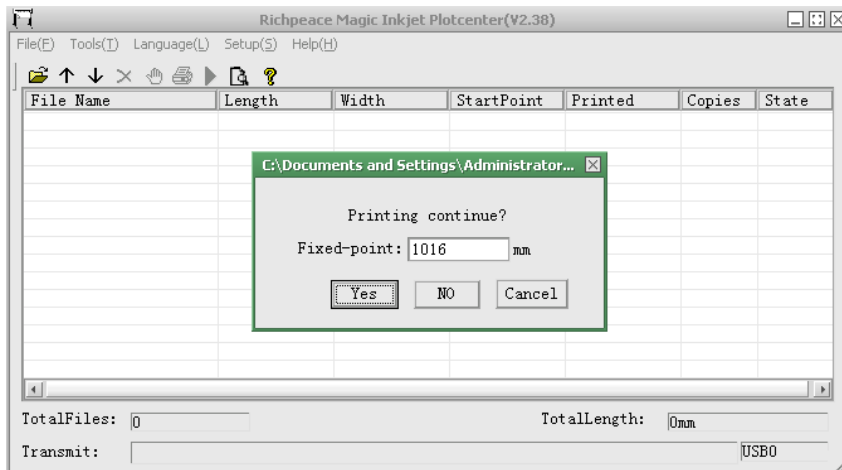

#### 4. Test

It can plot out a test graph.

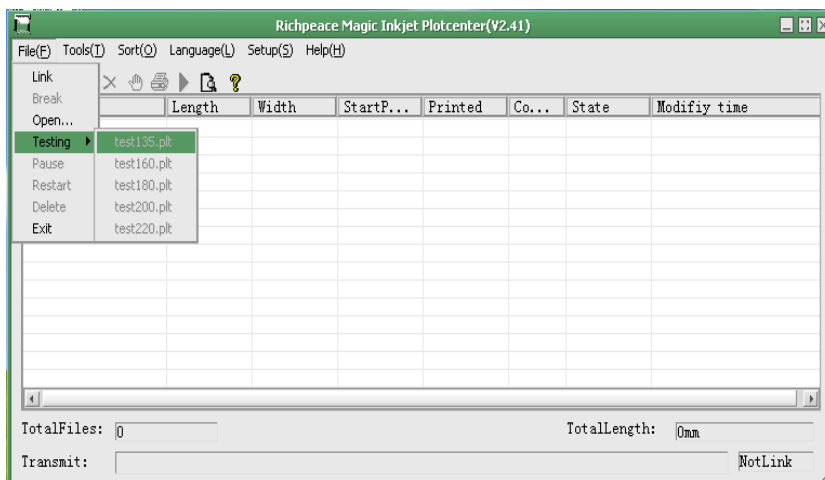

#### 5. Pause

It can stop sending data which is in the plotting sequence.

Choose the file which needs pause, then click pause.

After pause, the file will change from wait to pause.

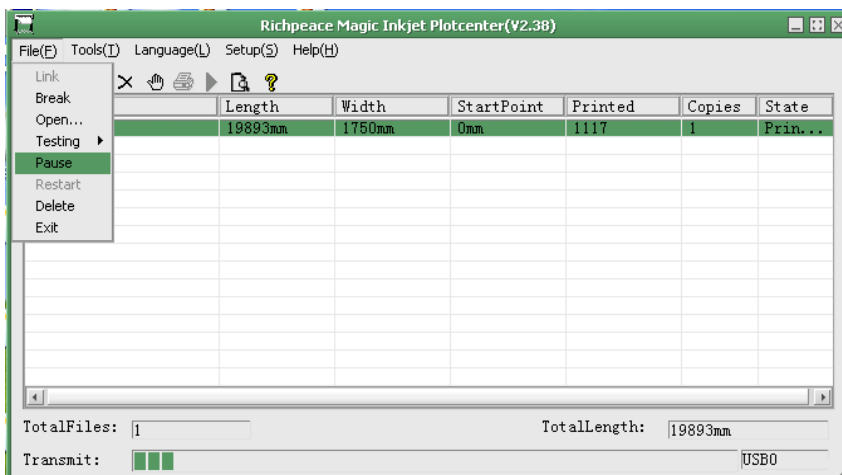

## 6 .Restart

Restart plotting the paused files.

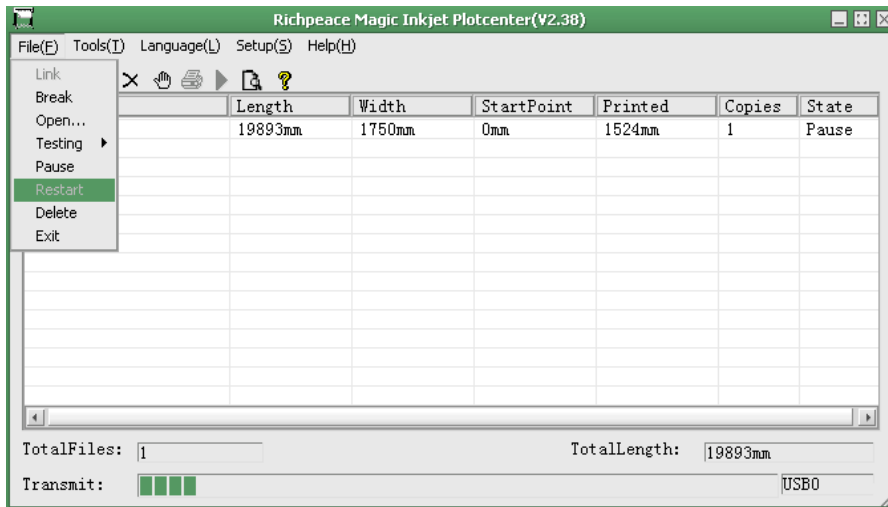

## 7. Delete

Delete the files in the sequence, if the file is plotting, the plotter will turn to the main screen.

Operation process as follows:

(1). Choose 'delete' menu in the plot menu, delete the file:

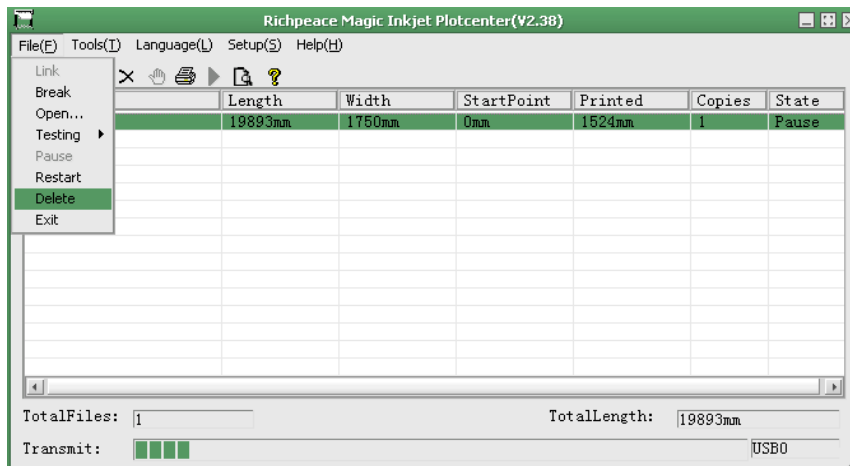

(2).Click Delete,the following dialogue will appear.

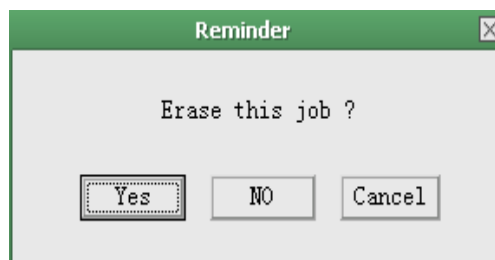

(3)Press 'Yes' to delete the file and the plotter will stop automatically; press 'No' not to delete the file and the plotter will keep on plotting.

## 8. Exit

If there are unfinished files, it will indicate as follows:

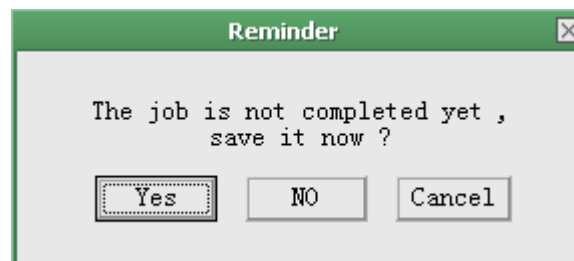
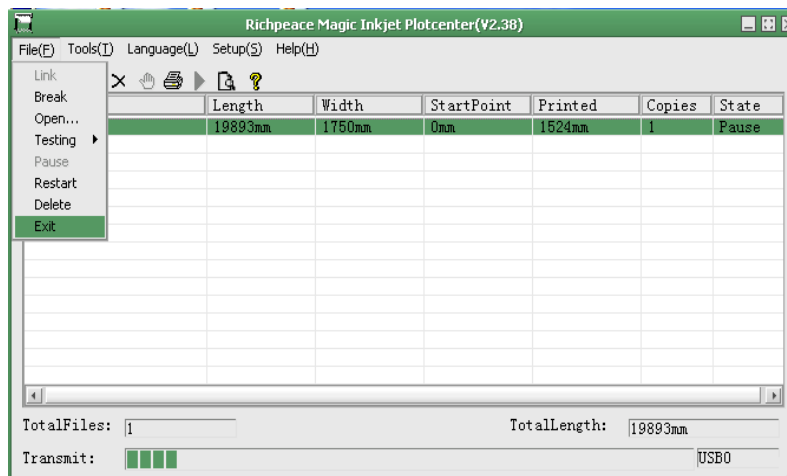

## 3.3 Tools

### 1. Input parameter

Input the mainboard parameter from the file PlotPara.ini in the plotcenter folder.

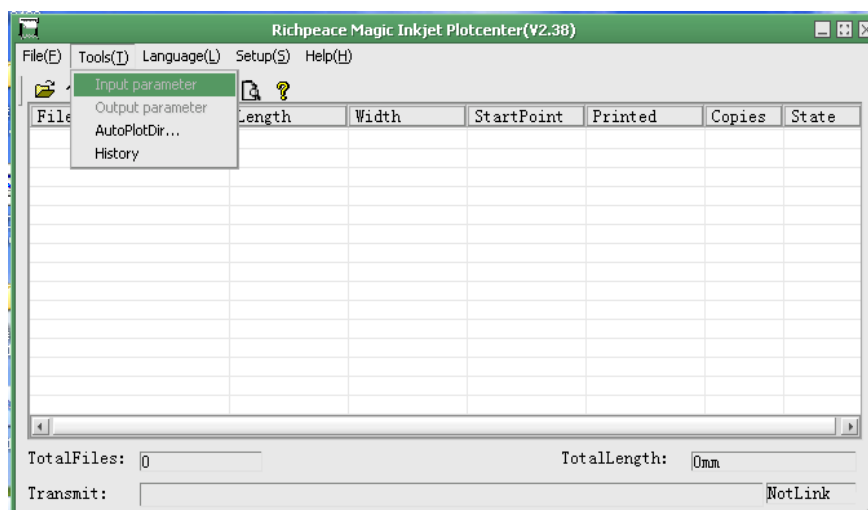

### 2. Output parameter

Output the mainboard parameter to the file PlotPara.ini in the plotcenter folder.

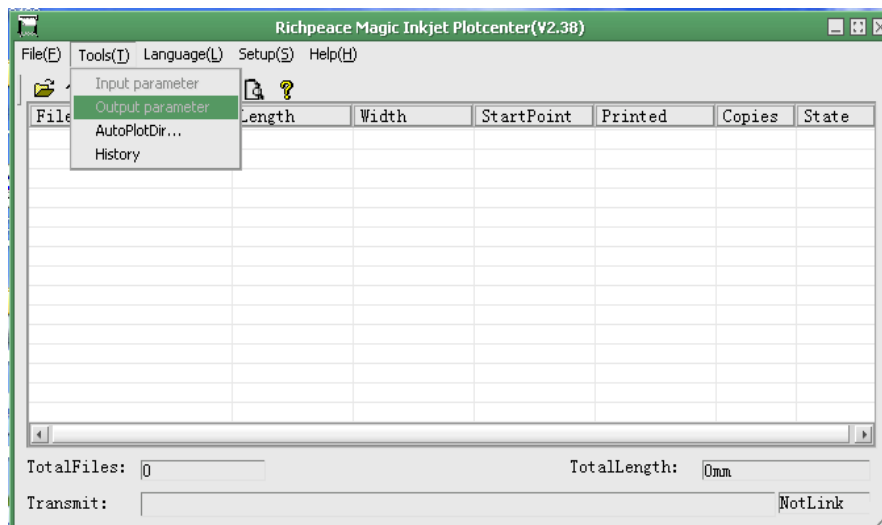

### 3. AutoPlotDir

1. Click AutoPlotDir Set the folder are already shared, then click OK, now the other computers can send the plotting files to the plotcenter to achieve the network plotting.

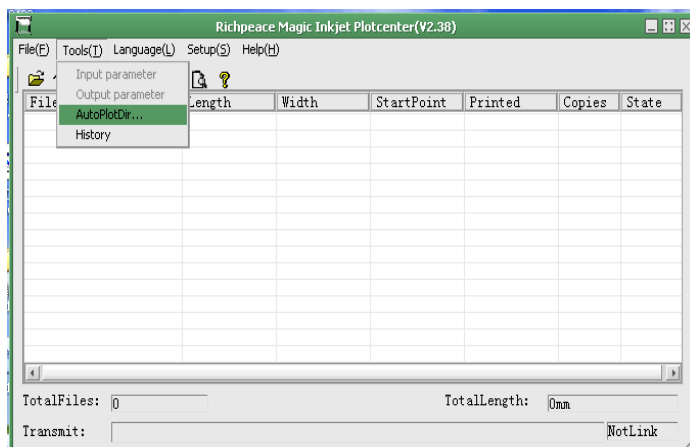

### 4 .History

The plotting history of the plotter:

Click History to get the following dialog, it will show you all the information that you have plotted out, if the files are still at the origin place, you can click 'plot' to plot again without opening again.

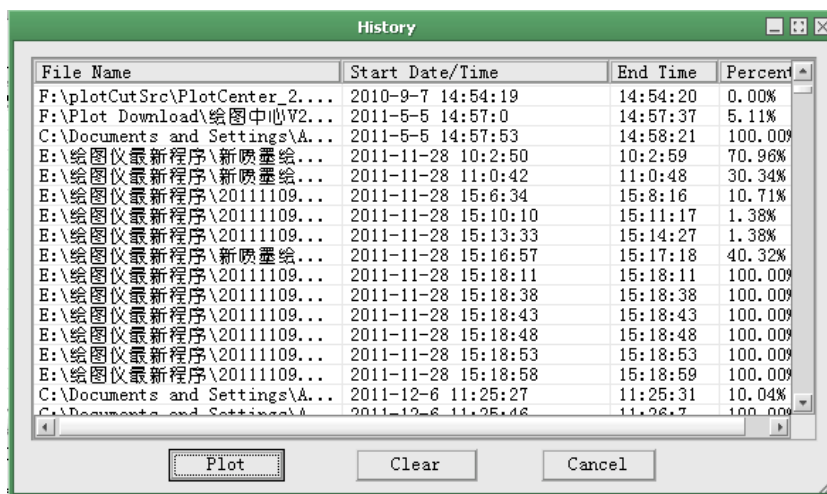
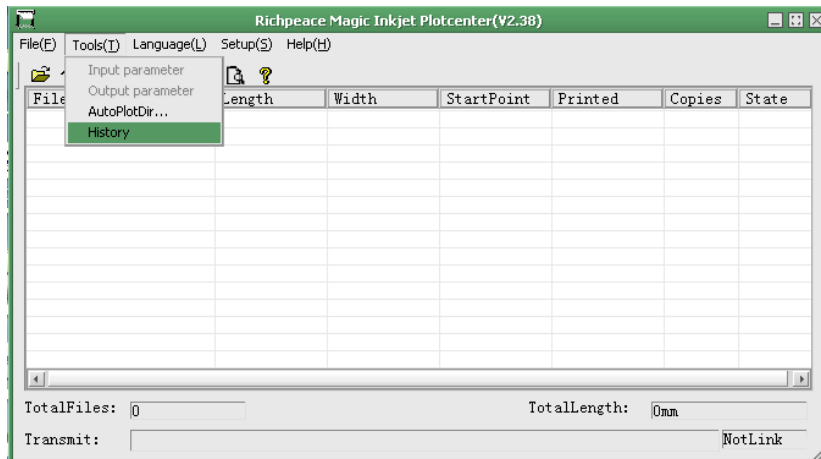

### 3.4 Language

We have two Languages for you to choose, English and Simplified Chinese

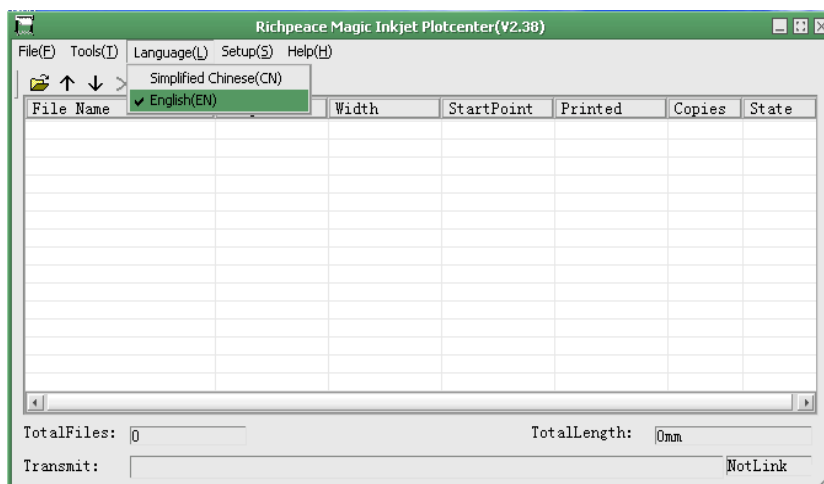

## 3.5 Setup

### 1. Communication setting

Communication setting in plotcenter means setting of plotter and computer, both of them must have uniform setting, otherwise it is impossible to communicate.

There are two communication models, USB and LAN, when it connected, USB and LAN will change to gray color, that means connection is normal and it can start to plot.

**USB** communication, if the plotter is using the USB cable communication, we need to change the options in the following dialog to USB.

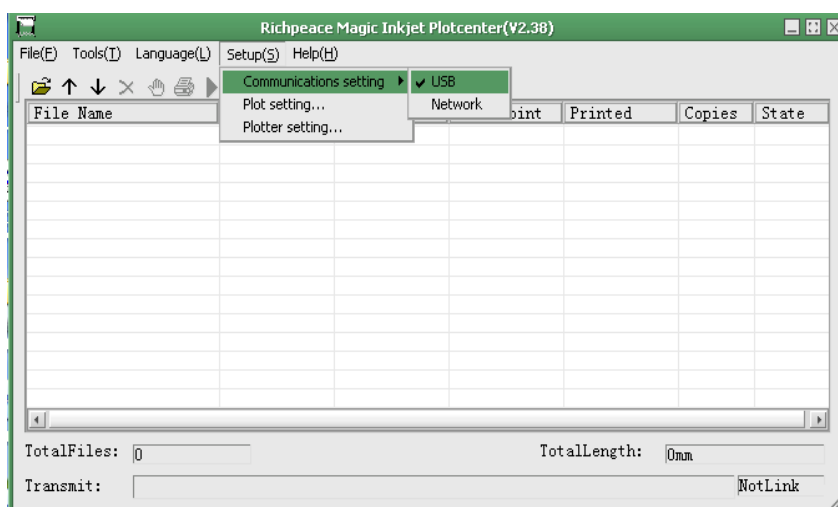

**LAN** communication, if the plotter is using the LAN cable communication, we need to change the options in the following dialog to Network.

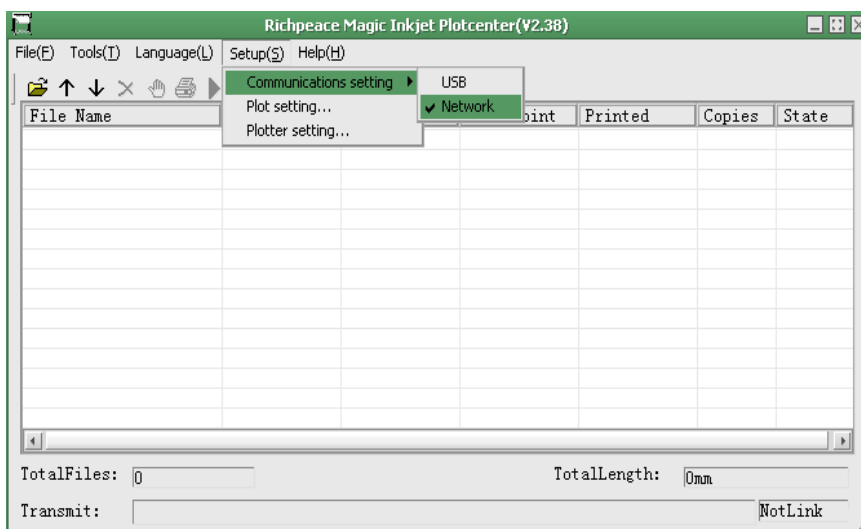

We must set the LAN parameter before connecting the plotter to the computer, here has three IP, computer IP,

plotcenter IP, plotter IP, the plotter IP and plotcenter IP are same, the computer IP is different with them, for example: computer IP is 192.168.1.A/255.255.255.0/192.168.1.1, the plotter/plotcenter IP should be 192.168.1.B/255.255.255.0/192.168.1.1, A and B must be different.

If all IP set up correct, open plotcenter again, the number of “set up” menu of each sub menu is new parameter instead of acquiescent.

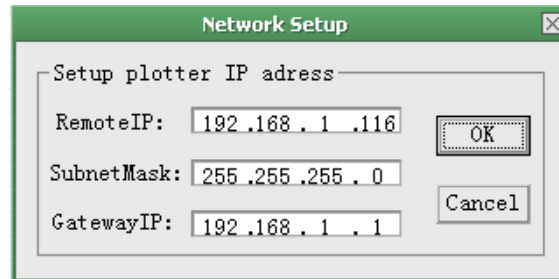

**Computer IP:** Set the computer IP according to the plotter IP or local area IP.

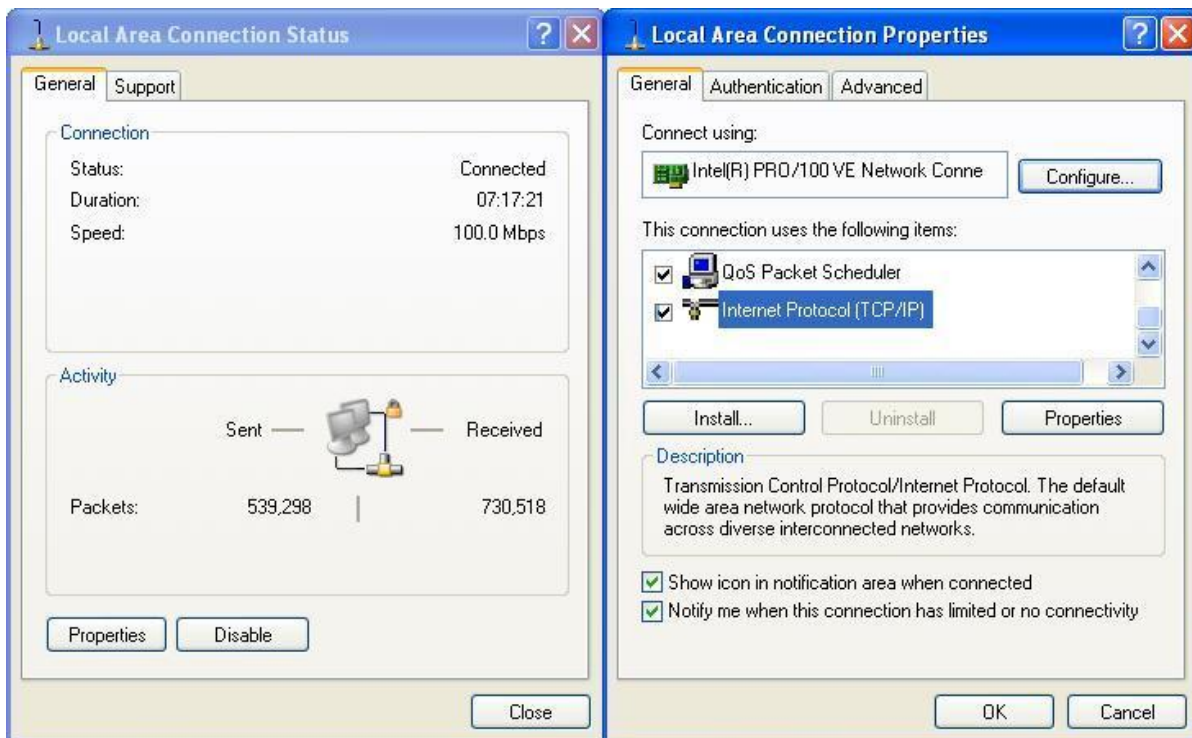



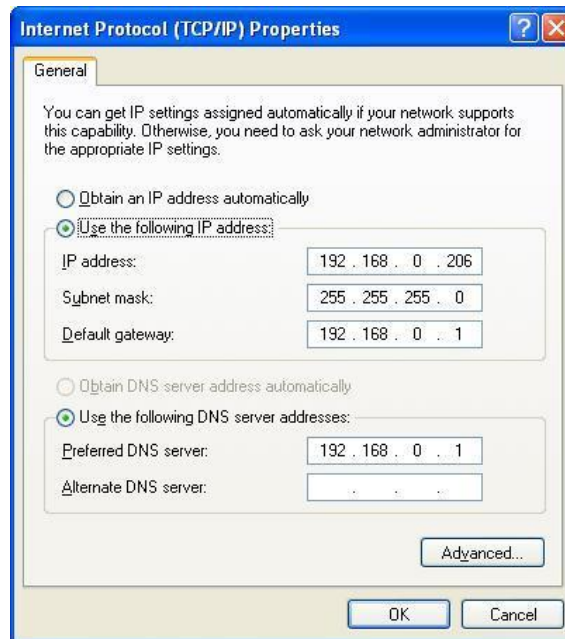

**Plotter IP:**

LCD displays:

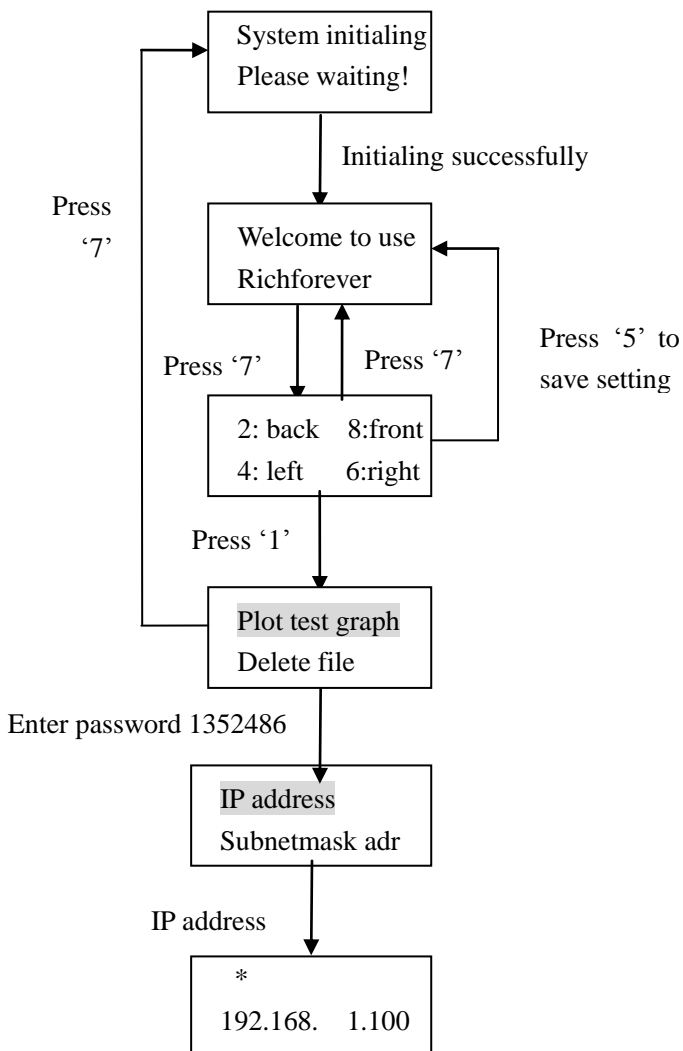

Operation process:

1. Turn on plotter, and it shows welcome to use enrich plotter.
2. Press '7' to pause the plotter. LCD displays to enter into the origin setting function.
3. Press '1' to enter into the basic menu.
4. Plotter enters into the advanced menu after inputting the password '1352486'.
5. Press '8' to choose IP address, subnetmask adr and gatewayip addr. Press '4' or '6' to move the cursor, press '2' or '8' to add/reduce the values.
6. Press '5' to save the modified values, press '7' to return back to the previous menu without saving modified values
7. Press '5' to save the modified values, press '7' to return back to the previous menu without saving modified values.
8. Save the modified values as backup.

### Plotcenter IP:

LAN setting of the plotcenter is the plotter's setting, they must be the same, or it can't connect to each other.

Operation process as follows:

1. Open the 'Setup' menu in the plotcenter:

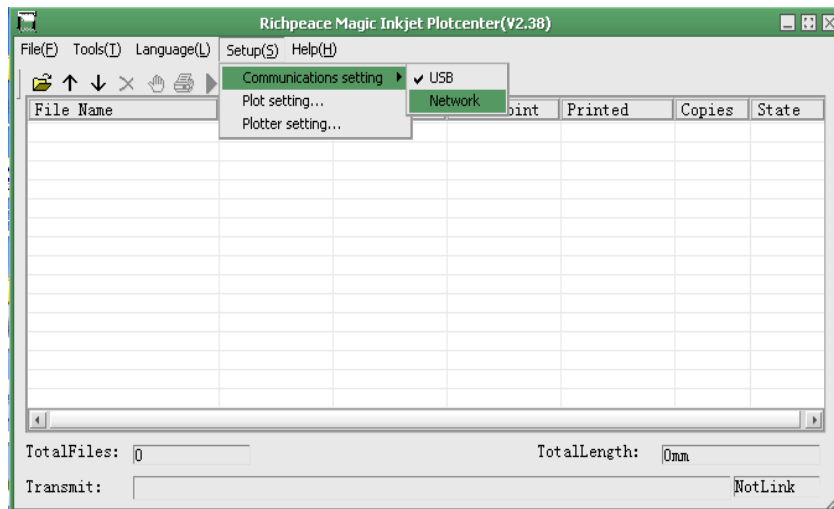

2. Choose 'Network' in the 'communications setting' menu, interface shows as follows:

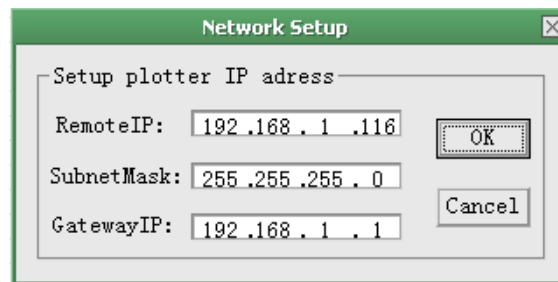

3. Modify the parameters of the 'Network setup' as plotter IP.  
when it connected, network setup will change to gray color.

## 2. Plot setting:

1. Click 'Setup' in the plotcenter dialog:

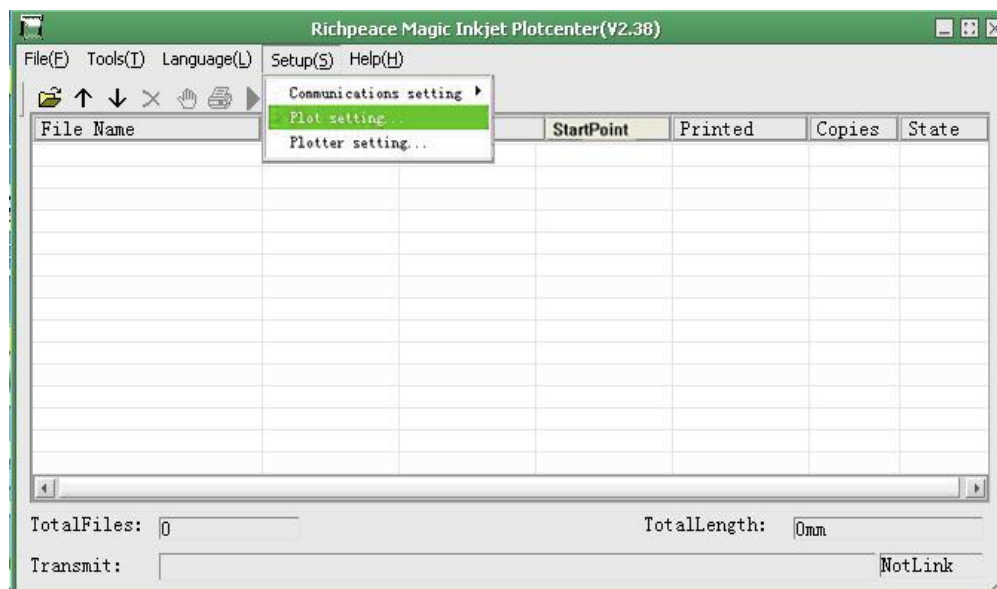

2. Click 'Plot setting' to get the following dialog:

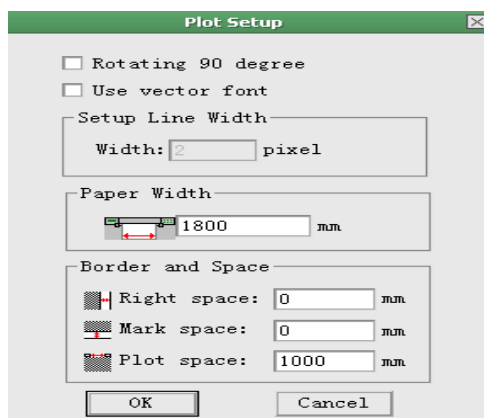

Rotating 90 degree: change the plotting direction

Use Vector font: use to make the font width same as the original

Setup line width: set the plotting line width

Paper width: set the maximum plotting width, if the marker width is wider than the paper width, the marker will be split to several parts and plot out.

Border and Space:

Right space: the space between the start plotting position and origin

Plot space: the margin between two markers

Mark space: the joint mark when the marker is split to several parts

## 3. Plotter setup

1. Click 'Setup' in the plotcenter dialog.

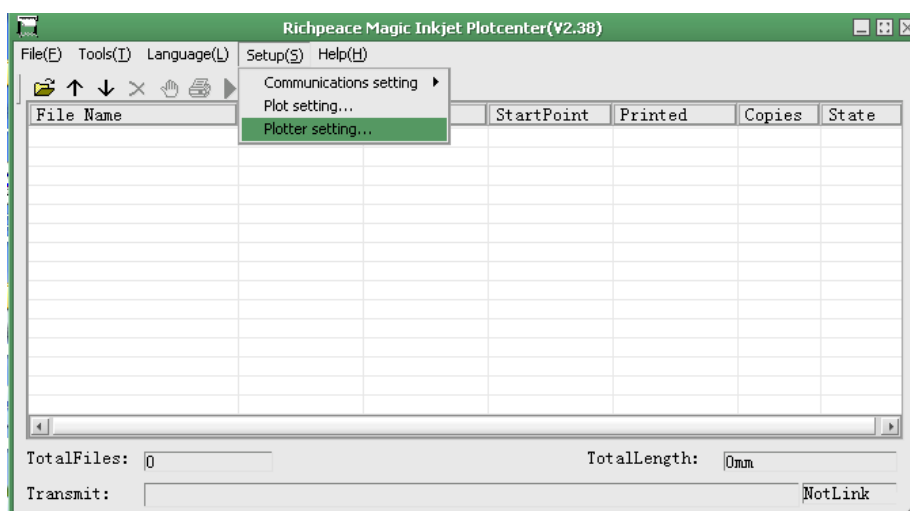

2. Click 'Plotter setting' to get the following dialog.

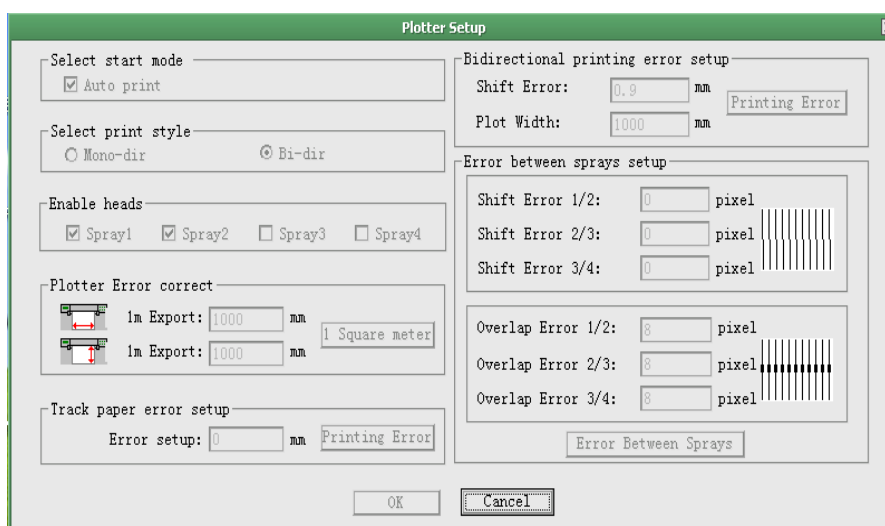

**Select print style:** it is for modifying the style, includes unidirectional and bidirectional. Unidirectional is only plotting from the right side to the left side, not plotting when return to the right side. Bidirectional is plotting from left side to the right side and right side to the left side.

Note: the default setting is bi-directional.

**Enable heads:** Choose the ink box number as you need, normally, if you use two ink boxes, choose no.1 and no.2, they must be together when using two ink boxes. If you use only one ink box, just choose no.1. If we use four ink boxes, we can choose 1,2,3,4 together.

**Bidirectional printing error setup:** set the shift between two scans

The plotting width can't be bigger than the real plotter plotting width.

**Error between sprays setup:** set the shift or overlap error between each two cartridges, the error is in one scan, shift error is in the horizontal direction, overlap error is in the vertical direction.

**Plotter error correct:** set the plotter calibration, output the 1meter rectangle and input the real measurement, please refer to **3.6 Calibration**.

**Plot and plotter setup:** Once setup correct, the following dialogue will appear:



### 3.6 Calibration

Operation as follows:

1. Plot out a 1meter rectangle and measure the length and width.
2. Choose the 'plotter setup' under the 'setup' menu and pop up the 'plotter setup' window.

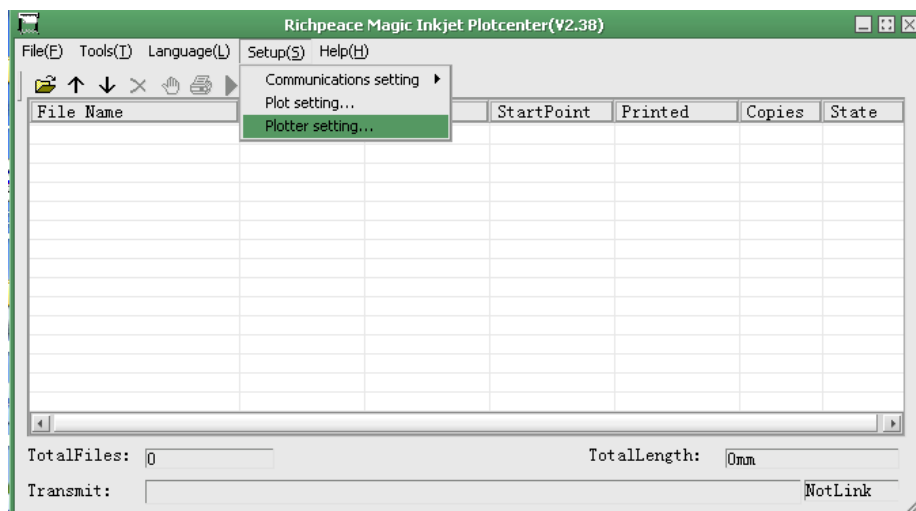

3. Input the actual length and width that you have measured to 'plotter error correct' dialog. Now the calibration is modified.

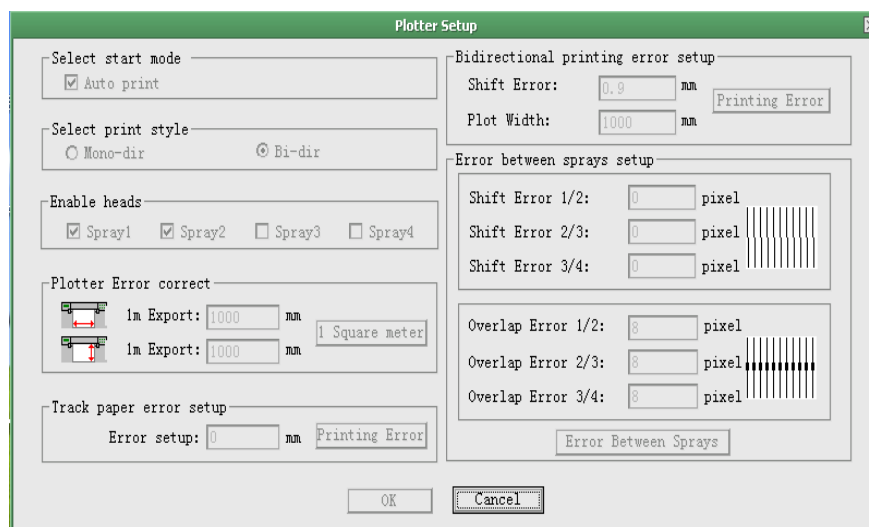

### 3.7 Plot sequence

When you plot several files continuously, you can change the plot order by clicking the 'Forward', 'Backward', 'Head', 'Tail' icons. Operations as follows:

1. For example, there are four files in the plotcenter, 1.plt, 2.plt, 3.plt, and 4plt.

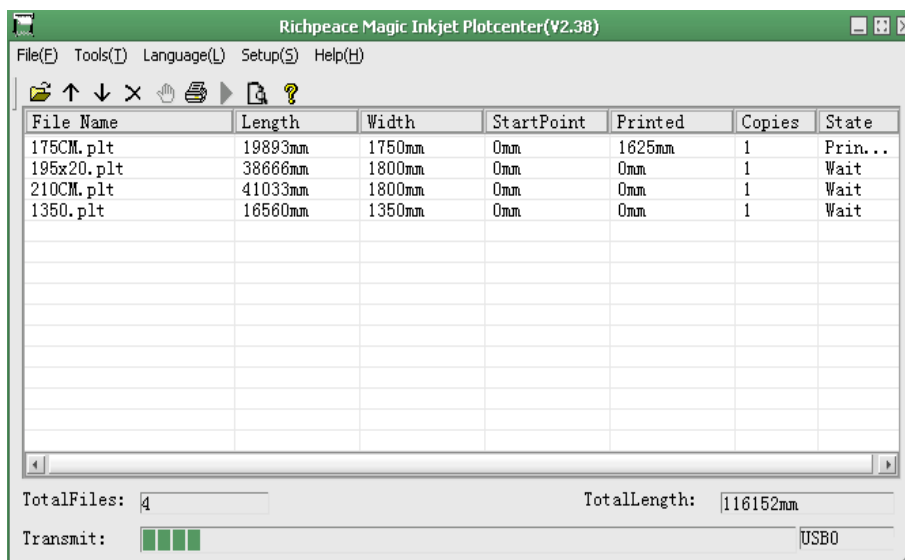

2. Press any one file that is not sending, the function of the file will be shown in the under four functions, forward, backward, head and tail is used to change the sequence of the files when the data is not sending.

**Caution:** files in the plotcenter are output as the normal sequence from upside to downside.

### 3.8 Print preview

Operation are as follows:

1. Press the selected print queue "wait" or "suspend".
2. Press "print preview" on the tool or press the right mouse button then press "print preview".

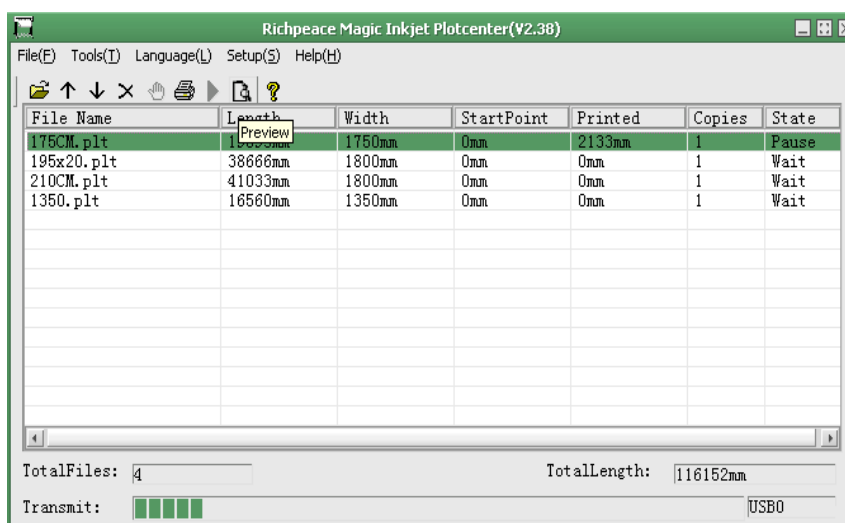

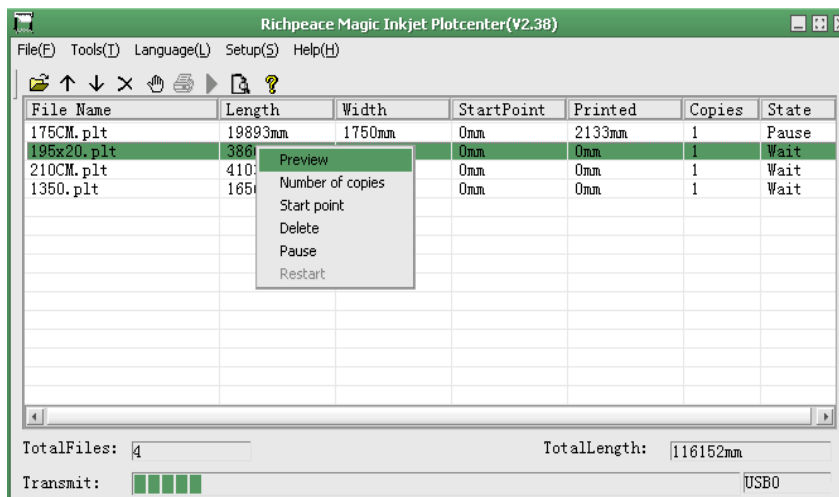

3.Press draw or close will bow out print preview menu.

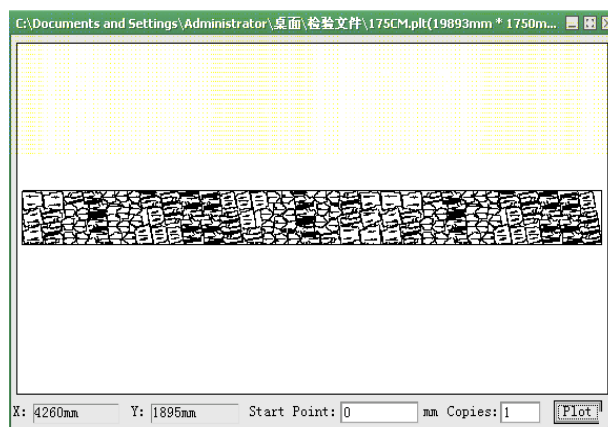

### 3.9 Operation after plotting

If you need plot other file when one marker is finished, you can also send the other file without close the plotcenter. If you want to finish plotting, you can take out the balance bar and cut off the paper, the cutting position as follows:

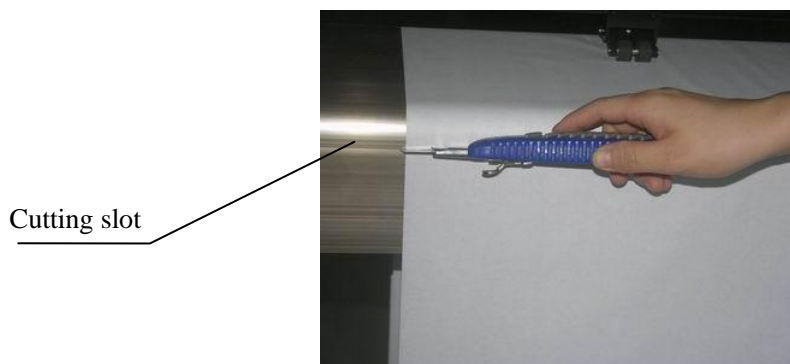

#### Caution

Don't cut off the paper in the other place, it may damage the plotter cover.

## **Chapter4 trouble shooting**

### **4.1 Error indication**

### **4.2 Note**



## 4.1 Error indication

The plotter can indicate the error on the LCD screen automatically if problem occurred, so it will help the operator to find solutions. Error indication and malfunction reason as follows:

### 1、 Paper out

Reason: When feeding paper or plotting, the 'feed paper start' sensor works.

Solution: Reinstall the paper and press '7'; the paper must be put in the correct position where the balance bar must be under the 'feed paper start'.

### 2、 Graph out of range

Reason: The width of the plotting marker is more than the printing range.

Solution: Check the file whether it is correct, makes sure the width of the marker is no more than the printing range; the origin position is too big, and modify the origin position.

### 3、 Origin sensor error

Reason: The origin sensor works abnormal when checking it. The origin sensor works abnormal when checking it. If the sensor still works when the print head moves to the left side that means the origin sensor is damaged. If the print head moves the max plotting width, but also can't sense the origin sensor that means the sensor is damaged.

Solution: Check the origin sensor whether it is damaged; check the print head whether it works fine.

Note: if the problem is still there when restarting the machine several times, please contact RICHFOREVER.

## 4.2 Note

1. Please put the balance bar under the 'feed paper start' sensor when turning on the plotter and reinstalling the paper.
2. Don't set origin when plotting.
3. It can't set the parameter setting when the data is not finished.
4. Don't send data to the plotter before initialing.
5. Don't feed paper or roll paper when plotting.
6. Please prevent the balance bar jumps out when you don't reinstall paper and press '7' to exit the paper out indication.
7. Don't shake the plotter when turn on the plotter.
8. Please keep the sensors position clear, don't block the sensors when plotting.
9. Please take out the ink box when the plotter will not be used in a long time to prevent the print head dirty and jammed.
10. Don't use wet, curly and edge turn up paper, and also the paper that has flaw.
11. The plotter uses HP51645A ink box, you can buy it in the hp franchise. Please use quality goods for good printing quality.
12. Never put hand and other goods beside the print head, or it may hurt person or influence the plotting quality.